

Your **Source** for **Effective**
Display and Merchandising



marketingIMPACT

L I M I T E D

displaypeople.com

ABOUT US

North America's premier supplier of retail merchandising and display products.

Since Marketing Impact opened in 1986, we have been helping retailers and manufacturers maximize product sales and simplify inventory management on shelves and sales floors across North America.

From cutting-edge custom displays to traditional merchandising products and accessories, we are your source for effective display and merchandising.

- Over 4,000 functional, adaptable, innovative merchandising and display products with complementary accessories.
- Large on-site inventory so most orders ship within 24 hours or less.
- Modern 60,000 square foot facility with comprehensive manufacturing capabilities.
- Experienced team of creative designers and engineers constantly developing functional, effective displays and merchandising products.
- Exceptional innovation and creativity to create the trends and keep us ahead of the global marketplace.
- Outstanding customer service, fast answers and effective solutions to even the most complex merchandising challenges.

This catalogue is full of comprehensive display and merchandising products. No matter what your merchandising and display requirements or needs may be, Marketing Impact has the products to help you maximize visibility and sales.

If you can't find exactly what you're looking for in this catalogue, please call us! Our knowledgeable staff will work with you to create the ideal merchandising solution.



HEAD OFFICE

50 Planchet Road
Concord ON Canada
L4K 2C7

TELEPHONE

(905) 738 - 0888
(800) 410 - 0264

FAX

(905) 738 - 1334

EMAIL

sales@displaypeople.com

TABLE OF CONTENTS

SIGN HOLDER SYSTEMS	9	LOSS PREVENTION	99
Sign Holder Frames	10	SlideGuard System	102
Modular Sign Holder Systems	12	HANGING RETAILERS	103
Mounting Accessories & Bases	14	The MAX Hanging Merchandising System	104
Popular Sign Holder Kits	22	Strip Retailers & Accessories	107
Floor Standing Sign Holders	26	DISPLAY COMPONENTS	111
Coil Mounts	30	Hooks, Hangers & Label Holders	117
Clear Sign Holder Solutions	31	Inventory Control Units	122
Hanging Boards	34	Hang Tabs	124
Aisle Markers	35	Ceiling Hangers	126
Card Clips	38	Suction Cups	128
Sign Holder & Base Clips	41	Fasteners	130
Clip-Ons	45	Floor Standing Merchandiser	132
BROCHURE HOLDERS & ACRYLIC ACCESSORIES	49	MERCHANDISING SOLUTIONS	137
Brochure & Business Card Holders	50	Multi-Purpose Bins & Accessories	138
Acrylic Accessories	53	Cooler Merchandising Racks	142
SHELF TICKETING STRIPS	57	Produce Bins	144
Ticketing Display Solutions	58	Inline Merchandising	144
KWICKLOAD® PUSHER SYSTEM	67	More Merchandising Ideas	147
Kwickload® Parts and Accessories	70	Standard Corrugated Displays	148
Kwickload® Cooler Accessories	72	Skid Fender	150
Popular Kwickload® Kits	73	Gift Card Spinners	150
MODULAR MERCHANDISING SYSTEMS	75	BEVERAGE SYSTEMS	151
Spring Loaded Pushers	76	Whole Bean Merchandising	152
Snap In Shelf Dividers	78	Gravity Pot and Merchandise Stands	152
Snap Bars	80	Condiment Trays	153
Popular Shelf Pusher Kits	81	Cup & Lid Organizers	154
Hanging/Shelf Mounted Pusher System	84	Accessories	155
Shelf Mounting Dividers	85	LIGHTING SYSTEMS	159
Shelf Management Mats & Trays	87	Lighting Parts	160
Hook Pushers	90	LED Lights	162
CD/DVD Pusher	91		
Extruded Gravity Feed/Pusher System Parts	93		
Pusher Fronts & Paddles	96		
Extruded Gravity Feed/Pusher System Kits	97		



Visit our website to learn more about our latest products and services.

www.displaypeople.com

NEW PRODUCTS

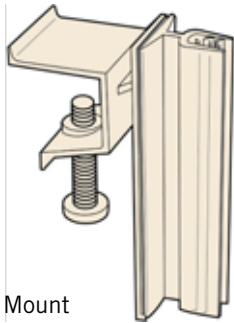

Channel Mount Gripper Sign Holder **p28**

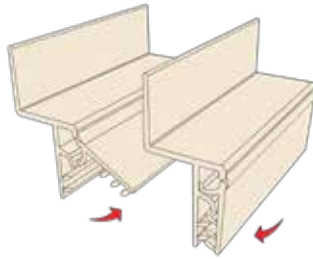

Z-Bar Slatwall Hanging Sign Gripper **p43**



Sliding Pin Divider **p85**



Channel Mount Gripper Sign Holder - Metal **p28**

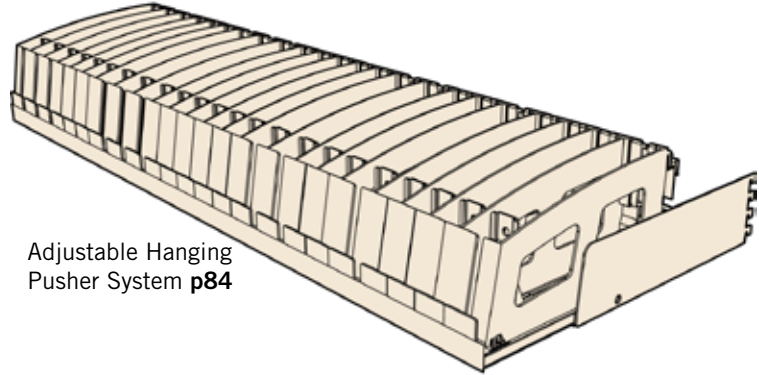

Adjustable Hanging Pusher System **p84**

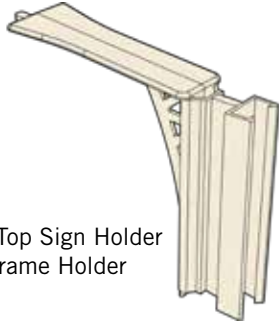

Shelf Top Sign Holder with Frame Holder **p36**

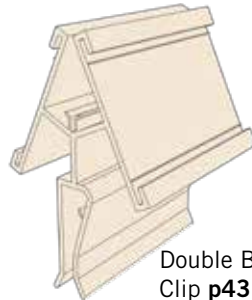

Double Basket Clip **p43**

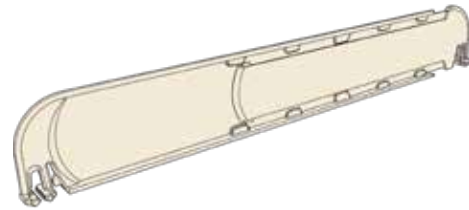

Gen2 Snap-In Adjustable Divider **p78**

SIGN HOLDER SYSTEMS

Channel Mount Gripper Sign Holder	28
Shelf Mount Gripper Sign Holder - Metal	28
Channel Mount Gripper Sign Holder - Metal	29
Under-Shelf Screw-Mount Gripper Sign Holder	29
Magnetic Under-Shelf Sign Holder with Gripper	29
Magnetic Under-Shelf Sign Holder with Hinge	29
Shelf Top Sign Holder with Frame Holder	36
Shelf Top Sign Holder with Sign Gripper	36
Double Basket Clip	43
Z-Bar Slatwall Hanging Sign Gripper	43
Boot System - Thin Poster Channel	44
Boot System - Heavy Duty Gripper Poster Channel	44
Boot System - Magnetic Base	44
Boot System - D-Tape	44
POP Sign Holder - Magnetic Base	45
POP Sign Holder - Square Base	46
POP Sign Holder with T-Clip - Dome Base	46
Hot Pan Clip	46

SHELF TICKETING STRIPS

Z-Bar Slatwall Hanging Sign Gripper	66
-------------------------------------	----

KWICKLOAD® PUSHER SYSTEM

Double Curved Pusher Front - Clear	71
Pusher Front with Label Holder - Clear	71
Small Pusher Front - Clear	71
Large Wide Pusher Front - Clear	72

MODULAR MERCHANDISING SYSTEMS

Gen2 Light Duty Pusher with Individual Fronts - 7/8" Wide	76
Gen2 Light Duty Pusher for Front Fence - 7/8" Wide	76
Gen2 Snap-In Adjustable Divider - 2" and 4"	78
Universal 2" Light Duty Pusher Kit	81
Slide and Lock Light Duty Pusher Kit	81
Adjustable Hanging Pusher System	84
Dividers for Hanging Pusher System	84
Pullout Shelf	85
Sliding Pin Divider	85
Seven Track Pusher Nail Tray	87
Small Pusher Front - Clear	96
Double Pusher Tray Rack	98

HANGING RETAILERS

Shelf-Top Hook for Flag or Flush Merchandising	105
Double Hanging Extension Bracket	105

NEW PRODUCTS

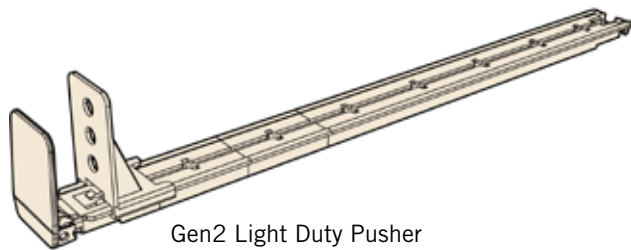

Gen2 Light Duty Pusher
with Individual Fronts **p76**

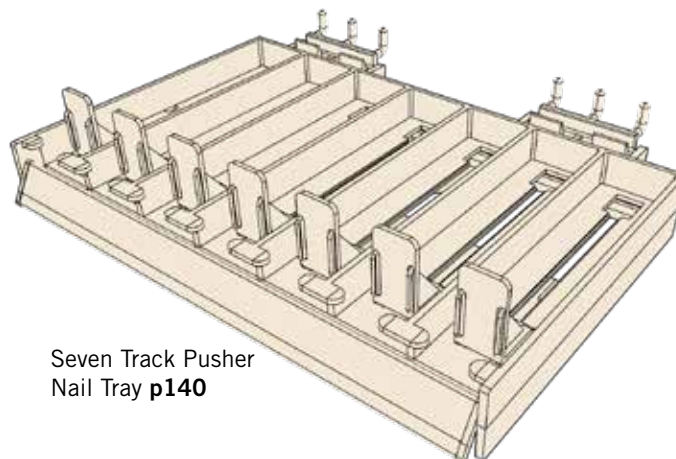

Seven Track Pusher
Nail Tray **p140**

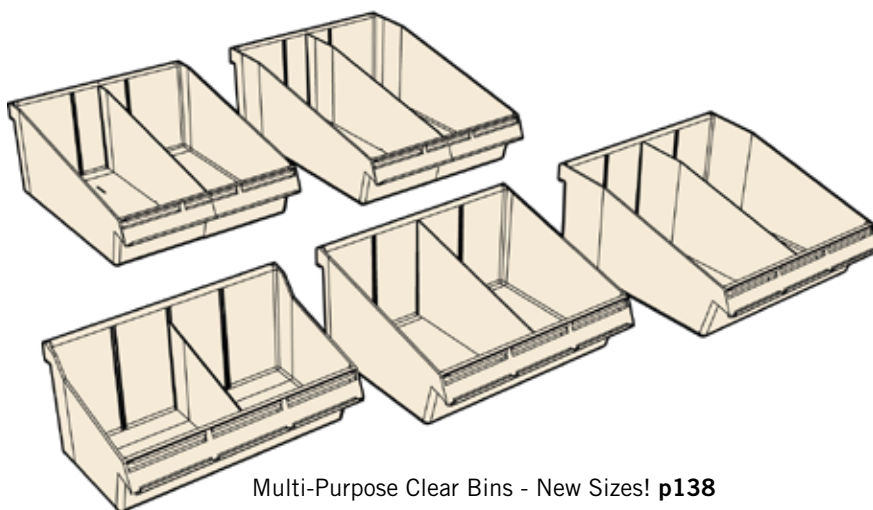

Multi-Purpose Clear Bins - New Sizes! **p138**

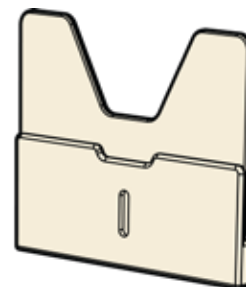

Pusher Front with Label Holder **p71**

DISPLAY COMPONENTS

Plastic Spiral Ring	112	Display Hook Product Stop	123
Plastic Overlap Ring	112	Round Inventory Control Unit	123
Magnetic Adapter	112	Snap-Out Pole Base	133
Magnetic Adapter with D-Tape	112	Knock Down Pole Base	133
Extra Heavy Duty Magnetic Adapter	113	Fiber Pole Foot	133
Corrugated Universal Butterfly Display Hook	117	Multi-Purpose Clear Bins	135
Corrugated Universal Display Hook	117	Clear Plastic Tub - 6" Diameter	136
Tapered Display Hook With Scan Plate	120	Slatwall Hanging Bowl	136
Tapered Display Hook With "C" Channel	120	Four-Tiered 14" Bowl Floor Display	136
Corrugated Universal Display Hook With "C" Channel	120	Four-Tiered 14" Tub Floor Display	136
Corrugated Universal Display Hook With Scan Plate	120		
Pegboard/Slatwall Display Hooks With "C" Channel	120	MERCHANDISING SOLUTIONS	
Corrugated Universal Display Hook With T-Scan Bar	121	Multi-Purpose Clear Bins	138
Pegboard/Slatwall Display Hooks With T-Scan Bar	121	Seven-Lane Pusher Nail Tray	140
All-Wire Pegboard Hook With Scan Hook	121	BEVERAGE SYSTEMS	
Single Prong All-Wire Pegboard Hook	121	Two Pot Thermal Riser	156
Shelf-Top Hook for Flag or Flush Merchandising	122	Counter K-Cup Displays	157
All-Wire Pegboard Hook With T-Scan Bar	122	Straw and Stir Stick Caddies	157
All-Wire Pegboard Hook With Scan Plate	122	Espresso Cup and Lid Holder	158
Inventory Control Tube	122	Tea Box Holder	158
Squeeze Style Inventory Control Unit	123	Spill Tray	158
Butterfly Hook Product Stop	123		

VIRTUAL STORE



- | | | | |
|---|--|--|--|
| 1 Sign Frame with Centre Stem Base p23 | 8 Clear Dual Extrusion p60 | 15 The MAX Hanger & Strip Retailers p104, p119 | 22 Sign Frame with Shovel Base p24 |
| 2 Gift Card Hanger p110 | 9 Sign Frame with Two Magnetic Stem Bases p23 | 16 Custom In-Aisle Pharmacy Spinner | 23 DVD / Video Games Pusher Box p91 |
| 3 Durable Vinyl Pouch Strip Retailer p109 | 10 Pharmacy Pusher Kit p87 | 17 Snap-In Divider with Front Stops p78 | 24 Interlocking Pusher Trays p89 |
| 4 Custom Cosmetics POP Sidewinder | 11 Invisi-Shield™ Standard Kit with Pushers p102 | 18 Snap Banner Track p147 | 25 Single Hook Snap-on Pusher p90 |
| 5 Custom Acrylic Cosmetic Displays | 12 Security Flip Door with Alarm p101 | 19 Strip Retailers & Mounting Hooks p119, p105 | 26 Loop Hook Snap-on Pusher p90 |
| 6 The Wobbler w/ Gondola and Shelf Top Mount p15 | 13 Gift Card Extender p110 | 20 Self-Centering Mount & Sign Gripper p21, p37 | 27 Large Divider p86 |
| 7 Cosmetics Tray p88 | 14 Sign Holder Frame w/ Wire & Bin Mount p10, p17 | | |

VIRTUAL STORE



- 22** Sign Frame with Self Centering Mount **p24**
- 23** Slide and Lock Light Duty Pusher Kit **p81**
- 24** Universal 2" Light Duty Pusher Kit **p81**
- 25** Shelf Mounted Bottle Pusher System **p82**
- 26** Shelf Mounted Bottle Pusher System **p82**
- 27** Custom POP Candy Sidewinder
- 28** Three Way Pillar Floor Standing Sign **p27**
- 29** Beverage Holder **p142**
- 30** The Wobbler w/ Glass Suction Mount **p15**
- 31** Vinyl Pouch Strip Retailer & Suction Hook **p109, p138**
- 32** Cooler Merchandiser Rack **p143**
- 33** Merchandiser Rack **p143**
- 34** Three Way Pillar Floor Standing Sign **p27**
- 35** Beverage Holder **p142**
- 36** The Wobbler w/ Glass Suction Mount **p15**
- 37** Vinyl Pouch Strip Retailer & Suction Hook **p109, p138**
- 38** Cooler Merchandiser Rack **p143**
- 39** Merchandiser Rack **p143**

- 1 Small Produce Bin **p151**
- 2 Sign Frame with Center Stem Base **p23**
- 3 Snap Banner Track **p147**
- 4 Produce Pusher Kit **p82**
- 5 The Wobbler with Clip-on Stem Base **p15**
- 6 Clip-on Spring Sign Holder **p47**
- 7 Deli Pusher Kit **p82**
- 8 Self-Centering Shelf Mount & Gripper **p21, p18**
- 9 Interlocking Pusher Trays **p89**
- 10 Medium Duty Pushers & 3" Front Fence **p77, p94**
- 11 Custom POP Candy Sidewinder
- 12 Custom POP Chocolate Tray
- 13 Wire Dump Bin **p138**
- 14 Kwickload® Confectionary Kit - Crossbar Mount **p80**
- 15 Clip-On Extended Spring Sign Holder **p48**
- 16 Snap-In Adjustable Dividers **p78**
- 17 Double Label Holder **p65**
- 18 Sign Frame with Two Magnetic Stem Bases **p23**
- 19 The Max with The Extended Max Hanger **p104, p104**
- 20 Beverage Holder **p142**
- 21 Merchandiser Rack **p143**
- 22 Sign Frame with Self Centering Under Shelf Mount" **p21**
- 23 Slatwall/Pegboard/Wire Shelf Frame Holder **p96**
- 24 Shelf Extender **p143**
- 25 Large Dividers **p86**
- 26 Shelf Mounted Bottle Pusher Kit **p82**
- 27 Universal Label Holder **p66**
- 28 The Max **p104**
- 29 DVD / Video Game Pusher Kit **p82**
- 30 The Max & The Max Hanger **p104, p104**
- 31 Gift Card Hanger **p110**
- 32 Single Hook Snap-On Pusher **p90**
- 33 Loop Hook Snap-On Pusher **p90**



- 34 Heavy Duty Pusher with Front Fence **p77, p94**
- 35 Custom POP Battery Display
- 36 The Max with Universal Bracket & The Max Card Holder **p104, p106**
- 37 Cosmetic Trays **p88**
- 38 Signholder Frame with Two Channel Clip Mounts **p10, p17**
- 39 Pegboard / Slatwall Extension Mount & Card Holder **p25, p18**
- 40 Custom POP Cosmetics Hanging Pegboard Display
- 41 Multi-Purpose Clear Bins **p138**
- 42 Custom POP Floor Display
- 43 Multi-Use Medium Duty Pusher with Clear Pusher Front **p77, p96**
- 44 Deodorant Pusher Kit **p87**
- 45 Small Dividers **p86**
- 46 Fold-N-Load™ Light Duty Pusher Kit for Pharmacy Products **p87**
- 47 Multi-Use Heavy Duty Pusher & Clear Pusher Front **p77, p96**
- 48 Snap-In Adjustable Divider with Front Stops **p79**
- 49 Custom POP Cosmetics Sidewinder
- 50 The Wobbler with Glass Suction Mount **p15**
- 51 Cooler Merchandiser Rack **p143**



Sign Holder Systems

The most versatile systems of their kind in North America, with solutions for any signage need.

Sign Holder Frames

Imperial and metric frames are moulded in high-impact styrene with mitered edges. Use horizontally or vertically. Standard colours include white, black, red and beige. Custom colours are also available (minimum order required).

	<h3>Imperial Frames</h3> <table border="1"> <tbody> <tr> <td>3½" x 5½"</td> <td>SHO355</td> </tr> <tr> <td>3¼" x 8¼"</td> <td>SHO358</td> </tr> <tr> <td>5" x 6"</td> <td>SHO56</td> </tr> <tr> <td>5½" x 7"</td> <td>SHO557</td> </tr> <tr> <td>7" x 11"</td> <td>SHO711</td> </tr> <tr> <td>8½" x 11"</td> <td>SHO85</td> </tr> <tr> <td>11" x 14"</td> <td>SHO114</td> </tr> <tr> <td>5½" x 24"</td> <td>SHOMMF5524</td> </tr> <tr> <td>5½" x 36"</td> <td>SHOMMF5536</td> </tr> </tbody> </table>	3½" x 5½"	SHO355	3¼" x 8¼"	SHO358	5" x 6"	SHO56	5½" x 7"	SHO557	7" x 11"	SHO711	8½" x 11"	SHO85	11" x 14"	SHO114	5½" x 24"	SHOMMF5524	5½" x 36"	SHOMMF5536		
3½" x 5½"	SHO355																				
3¼" x 8¼"	SHO358																				
5" x 6"	SHO56																				
5½" x 7"	SHO557																				
7" x 11"	SHO711																				
8½" x 11"	SHO85																				
11" x 14"	SHO114																				
5½" x 24"	SHOMMF5524																				
5½" x 36"	SHOMMF5536																				
	<h3>Sign Frame with Back</h3> <p>Frame includes molded back with mounting holes.</p> <table border="1"> <tbody> <tr> <td>7"H x 11"W</td> <td>SHOB711</td> </tr> <tr> <td>8½"H x 11"W</td> <td>SHOB8511</td> </tr> </tbody> </table>	7"H x 11"W	SHOB711	8½"H x 11"W	SHOB8511																
7"H x 11"W	SHOB711																				
8½"H x 11"W	SHOB8511																				
	<h3>Metric Frames</h3> <table border="1"> <tbody> <tr> <td>220 mm x 185 mm</td> <td>SHOMA1</td> </tr> <tr> <td>279 mm x 219 mm</td> <td>SHOMA4</td> </tr> <tr> <td>210 mm x 148 mm</td> <td>SHOMA5</td> </tr> <tr> <td>148 mm x 105 mm</td> <td>SHOMA6</td> </tr> </tbody> </table>	220 mm x 185 mm	SHOMA1	279 mm x 219 mm	SHOMA4	210 mm x 148 mm	SHOMA5	148 mm x 105 mm	SHOMA6												
220 mm x 185 mm	SHOMA1																				
279 mm x 219 mm	SHOMA4																				
210 mm x 148 mm	SHOMA5																				
148 mm x 105 mm	SHOMA6																				
	<h3>Frameless Sign Holder</h3> <p>Compatible with all mounting accessories. Can be used horizontally or vertically. Open on three sides for convenience. Frame base is available in white, black, red and clear.</p> <p style="text-align: right;">US Patent #5625969</p> <table border="1"> <tbody> <tr> <td>3½"H x 5½"W</td> <td>CLFRALAN355</td> </tr> <tr> <td>5½"H x 7"W</td> <td>CLFRALAN557</td> </tr> <tr> <td>7"H x 11"W</td> <td>CLFRALAN711</td> </tr> <tr> <td>8½"H x 11"W</td> <td>CLFRALAN851</td> </tr> <tr> <td>11"H x 14"W</td> <td>CLFRALAN114</td> </tr> <tr> <td>5½"H x 3½"W</td> <td>CLFRAPOR355</td> </tr> <tr> <td>7"H x 5½"W</td> <td>CLFRAPOR557</td> </tr> <tr> <td>11"H x 7"W</td> <td>CLFRAPOR711</td> </tr> <tr> <td>11"H x 8½"W</td> <td>CLFRAPOR851</td> </tr> <tr> <td>14"H x 11"W</td> <td>CLFRAPOR114</td> </tr> </tbody> </table>	3½"H x 5½"W	CLFRALAN355	5½"H x 7"W	CLFRALAN557	7"H x 11"W	CLFRALAN711	8½"H x 11"W	CLFRALAN851	11"H x 14"W	CLFRALAN114	5½"H x 3½"W	CLFRAPOR355	7"H x 5½"W	CLFRAPOR557	11"H x 7"W	CLFRAPOR711	11"H x 8½"W	CLFRAPOR851	14"H x 11"W	CLFRAPOR114
3½"H x 5½"W	CLFRALAN355																				
5½"H x 7"W	CLFRALAN557																				
7"H x 11"W	CLFRALAN711																				
8½"H x 11"W	CLFRALAN851																				
11"H x 14"W	CLFRALAN114																				
5½"H x 3½"W	CLFRAPOR355																				
7"H x 5½"W	CLFRAPOR557																				
11"H x 7"W	CLFRAPOR711																				
11"H x 8½"W	CLFRAPOR851																				
14"H x 11"W	CLFRAPOR114																				



Clear Vinyl Pocket Sign Holders

Clear, rigid PVC pockets hold and protect standard size signs. Opening on one side. Can be used with Strip Mount or Multi-Use Coil Mount to attach to most shelves. Custom colours available (minimum order required).

2¼"H x 3½"W	DSP35225
3½"H x 5"W	DSP355
4"H x 6"W	DSP46
5½"H x 7"W	DSP557
3½"H x 8½"W	DSP8535
5½"H x 8½"W	DSP8555
7"H x 11"W	DSP117
8½"H x 11"W	DSP8511
22"H x 28"W	DSP2228



Clear Vinyl C-Channel Sign Holders

3½"H x 5"W	CCHANNELHLDR5X3
5"H x 7"W	CCHANNELHLDR5X7
7"H x 11"W	CCHANNELHLDR711

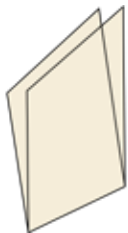

Clear Vinyl Foldover Sign Holders

3½"H x 5½"W	FOLDOVER3555
5½"H x 7"W	FOLDOVER557
7"H x 11"W	FOLDOVER711
8½"H x 11"W	FOLDOVER8511
11"H x 14"W	FOLDOVER114



Front Loading Aluminum Snap Frame

Available in various colours and sizes, this sign is built to last. Its simple design allows for easy graphic interchangeability. These snap frames are front loading, easy to hang and sure to make any store message or advertisement stand out.

7" x 11"	ALUSNAP0711
8½" x 11"	ALUSNAP8511
11" x 14"	ALUSNAP1114
11" x 17"	ALUSNAP1117
18" x 24"	ALUSNAP1824
22" x 28"	ALUSNAP2228

How It Works: Reusable Magic Frame

The Reusable Magic Frame is a quick, clean and easy way to hang signage on any smooth flat surface. A special molecular gel allows repeated use while providing a secure attachment to walls or counters. No residual adhesive left behind! Easily display signs on:

- Cooler Doors
- Windows
- Deli Cases
- Any smooth flat surface



Sticks to any smooth surface



No residue is left behind when removed

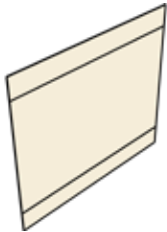

Reusable Magic Frame

Eliminate messy tape from your windows. Magic frame stays up in hot or cold weather, unlike suction cups. Display two-sided signs. Durable Clear plastic with white border or black. Custom colours available (minimum order required).

3½"W x 5½"H	RSH03555
5½"H x 8½"W	RSH08555
7"H x 11"W	RSH00711
8½"H x 11"W	RSH08511
11"H x 17"W	RSH01711
22"H x 28"W	RSH02228

Modular Sign Holder Systems

In-store advertising is simple and effective with our full line of sign holders and accessories. For shelves, slatwall, pegboard, glass or mounted directly on your merchandise, we have a signage solution for your specific needs.

Manufactured from high-impact styrene and in variety of colours, they're built to last.



How It Works: Modular Signage Solutions

Select the size frame:

We stock a wide variety of frames in both imperial and metric sizes. Our patented locking mechanism keeps the sign securely in place, allowing you to display the frame vertically or horizontally.



+

Add a base and accessories:

Our bases and mounting accessories let you tailor the frame to suit your specific application.

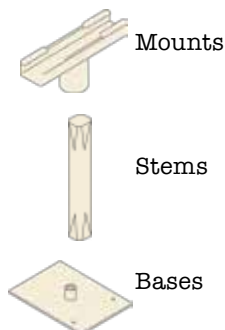

=

The perfect signage solution:

With our combination of frame sizes, accessories and experience, we can help you with solutions to all your sign display needs.





Four-Way Frame Kit

Kit Includes:
 4 – 7”H x 11”W Frames
 4 – Frame Connectors
 4 – Clear Vinyl Foldovers
 Specify colours when placing order.

FOURWAY117



Three-Way Sign Holder Kit

Standard Kit Includes:
 3 - Frames
 3 - Frame Connectors
 3 - Clear Vinyl Foldovers
 Available in black, red or white. Custom colours available (minimum order required).

3½” x 5”	THREEWAYKIT355
5½” x 7”	THREEWAYKIT557
7” x 11”	THREEWAYKIT711
8½” x 11”	THREEWAYKIT851
11” x 14”	THREEWAYKIT114

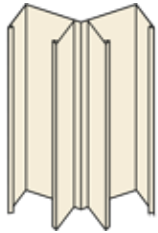

Three-Way Frame Connector

Moulded in PVC. Available in black, red, white and clear.

SHE2498



Three-Way Countertop Sign Holder

Kit Includes:
 3 - 11”H x 7”W Frames
 3 - Frame Connectors (SHE2498)
 2 - Center Bases
 1 - 6” Stem
 Specify colours when placing order.

CTS0711-06

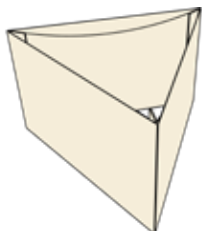

Three-Way Co-Poly Sign Holder





Top loading, clear triangular sign holder for signage measuring 7”H x 11”W.
 Custom sizes available (minimum order required).

7”H x 11”W	TRI1107
------------	---------

Mounting Accessories & Bases

In-store advertising is simple and effective with our full line of sign holders and accessories. For shelves, slatwall, pegboard, glass or mounted directly on your merchandise, we have a signage solution for your specific needs.

Manufactured from high-impact styrene and in variety of colours, they're built to last.

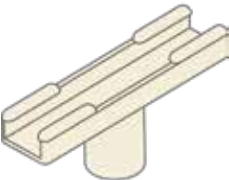
	<h3>Telescopic Pole Mount</h3> <p>Chrome tube construction attaches to any base or standard fixture. Stem mount (SHA010) sold separately.</p> <table border="1"> <tbody> <tr> <td>12" - 24"</td> <td>SHB018-SHORT</td> </tr> <tr> <td>15" - 30"</td> <td>SHB018</td> </tr> <tr> <td>24" - 48"</td> <td>SHB020</td> </tr> <tr> <td>36" - 72"</td> <td>SHB019</td> </tr> </tbody> </table>	12" - 24"	SHB018-SHORT	15" - 30"	SHB018	24" - 48"	SHB020	36" - 72"	SHB019						
12" - 24"	SHB018-SHORT														
15" - 30"	SHB018														
24" - 48"	SHB020														
36" - 72"	SHB019														
	<h3>Stem</h3> <p>Available in seven standard lengths.</p> <table border="1"> <tbody> <tr> <td>2" (51mm)</td> <td>SHA020</td> </tr> <tr> <td>4" (101mm)</td> <td>SHA003</td> </tr> <tr> <td>6" (152mm)</td> <td>SHA005</td> </tr> <tr> <td>8" (203mm)</td> <td>SHA004</td> </tr> <tr> <td>10" (254mm)</td> <td>SHA001</td> </tr> <tr> <td>12" (304mm)</td> <td>SHA002</td> </tr> <tr> <td>15" (381mm)</td> <td>SHA015</td> </tr> </tbody> </table>	2" (51mm)	SHA020	4" (101mm)	SHA003	6" (152mm)	SHA005	8" (203mm)	SHA004	10" (254mm)	SHA001	12" (304mm)	SHA002	15" (381mm)	SHA015
2" (51mm)	SHA020														
4" (101mm)	SHA003														
6" (152mm)	SHA005														
8" (203mm)	SHA004														
10" (254mm)	SHA001														
12" (304mm)	SHA002														
15" (381mm)	SHA015														
	<h3>Stem Connector</h3> <p>Connects two stems together for extra length.</p> <table border="1"> <tbody> <tr> <td></td> <td>SHA006</td> </tr> </tbody> </table>		SHA006												
	SHA006														
	<h3>Threaded Stem Adapter</h3> <p>Connects a stem to your existing threaded fixture.</p> <table border="1"> <tbody> <tr> <td></td> <td>SHA008</td> </tr> </tbody> </table>		SHA008												
	SHA008														
	<h3>Stem Mount</h3> <p>Connects a frame to a stem.</p> <table border="1"> <tbody> <tr> <td></td> <td>SHA010</td> </tr> </tbody> </table>		SHA010												
	SHA010														



How It Works: The Wobbler

The Wobbler is one of our most versatile sign holders. Signs hang directly from the Wobbler's hook for an interesting free-floating effect. The curved stem can hang signs above and in front of products sitting on shelves or hanging on pegboard or wire. Moulded in polycarbonate, the Wobbler is available in clear, black and white. Custom colours also available (minimum order required).

Includes:

- Mount
- 15" Stem
- Connector and Curved Wobbler

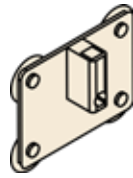

Wobbler - Glass Mount

Wobbler with 4 suction cups for attaching signage to a flat surface.

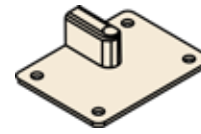

Wobbler - Gondola Mount

Wobbler with mount for attaching signage to a slatwall.

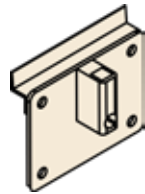

Wobbler - Slatwall Mount

Wobbler with 4 push pins for attaching signage to pegboard.

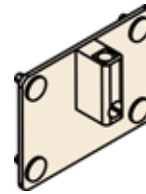

Wobbler - Pegboard Mount

Wobbler with base and curved stem for attaching signage to a gondola or shelf top.



The Wobbler

The Wobbler - Glass Mount	Clear	WOBBLERCL-GLASS
The Wobbler - Slatwall Mount	Clear	WOBBLERCL-SLAT
The Wobbler - Gondola Mount	Clear	WOBBLERCL-GON
The Wobbler - Pegboard Mount	Clear	WOBBLERCL-PEG



Bottle Top Holders

Works with sign holders and Wobblers.



Fits 1" Bottle Tops	BOTTLETOP01
Fits 1¼" Bottle Tops	BOTTLETOP02



Clip-On Stem Base for Wire Grid / Basket Frame

Mounts to wire and holds a variety of our sign holders including the Wobbler.

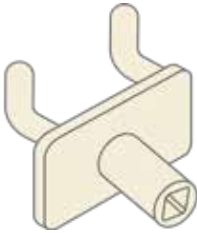
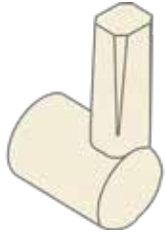
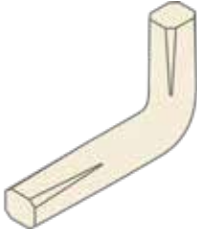
SHB131

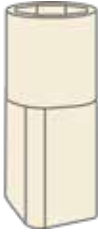
	<p>Clip-On Stem Base</p> <p>Mounts to a flat fence and holds a variety of our sign holders including the Wobbler.</p> <p>SHB130</p>
	<p>Pegboard / Slatwall Mount</p> <p>Fits flush to standard pegboard and slatwall.</p> <p>Fits 1/8" Pegboard SHA021A Fits 1/4" Pegboard SHA021</p>
	<p>Elbow - 90°</p> <p>Connects stem to frame at a 90° angle.</p> <p>SHA011</p>
	<p>Male-Male Stem - 90°</p> <p>For various signage applications.</p> <p>SHA048</p>
	<p>Pivoting Stem Connector</p> <p>Allows a frame to pivot up to 90° so the sign can be read from above or below.</p> <p>SHA049</p>
	<p>Stem Mount Reducer</p> <p>Makes a standard 1/2" fixture compatible with our stems.</p> <p>SHA050</p>

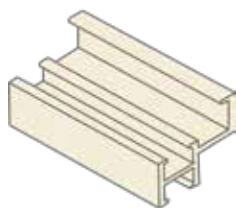

Slatwall Mount

For most slatwall installations. Moulded in clear PVC. (Sold in Packs of 25)

Pack of 25

SHA030

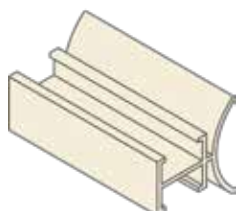

Channel Clip Mount

For use with most 1¼" price channels. Moulded in clear PVC. (Sold in Packs of 25)

Pack of 25

SHA017

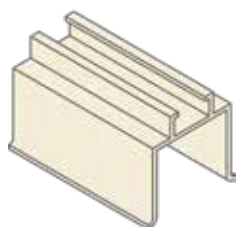

Saddle Clip Mount

For racks, gondolas and other fixtures. Moulded in clear PVC. (Sold in Packs of 25)

1"W

SHA012

½"W

SHA013

1½"W

SHA1502

1¾"W

SHA1752

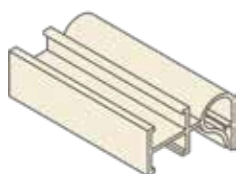

Wire / Bin Mount

Clips your sign to a wire bin or rack. (Sold in Packs of 25)

SHA016

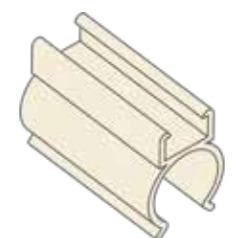

Tube-Clip Mount

For ¾" to 1" tubes. Moulded in clear PVC. (Sold in Packs of 25)

1" diameter

SHA014CLEAR

¾" diameter

SHA014CLEAR-SM

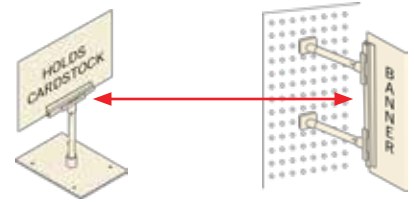

How It Works: Strip Mount Card Holder

We like to design versatility into all our products, including the popular Strip Mount Card Holder. It grips cardstock 10 pt. - 30 pt. or a Pocket Sign Holder simply and easily. The Strip Mount also makes a great Aisle Marker when used with one of our Self-Centring Mounts. It can even be used as a gondola topper!

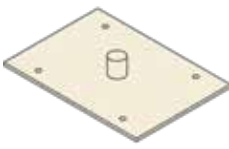
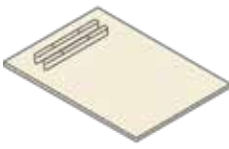
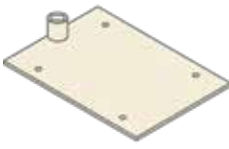
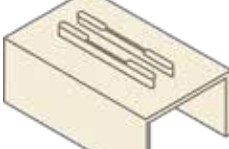

SHE2101: Strip Mount Card Holder

	<h3>Strip Mount Card Holder</h3> <p>Compatible with our modular sign holder systems. Available in lengths 1" to 48" long. Available in clear, black and white.</p> <p style="text-align: right;">SHE2101</p>	
	<h3>Wire Fence Clip</h3> <p>Clips your sign to a wire bin or rack. Requires Frame Mount SHA041</p> <p style="text-align: right;">SHA040</p>	
	<h3>C-Channel Pivoting Connector</h3> <p>Connects your sign directly to a C-Channel. Requires Frame Mount SHA041</p> <p style="text-align: right;">SHA042</p>	
	<h3>Frame Mount</h3> <p>For use with Wire Fence Clip (SHA024) or C-Channel Pivoting Connector (SHA042)</p> <p style="text-align: right;">SHA041</p>	
	<h3>Carton/Basket Clip</h3> <p>For wire racks, bins, cartons, upright dividers and similar surfaces. Pivots to any angle. Moulded in clear PVC.</p> <p style="text-align: right;">SHB038</p>	

	<p>Flat Base</p> <p>For tables, counters, shelves and other flat surfaces.</p> <p>SHB001</p>
	<p>Center Stem Base</p> <p>For tables, counters, shelves and other flat surfaces.</p> <p>SHB002</p>
	<p>Flat Shovel Base</p> <p>For end caps and bulk merchandise displays.</p> <p>SHB005</p>
	<p>Single Stem Shovel Base</p> <p>For stem signage on end caps and bulk displays. Pre-drilled holes in corners.</p> <p>SHB006</p>
	<p>Gondola Center Flat Base</p> <p>Custom formed to fit any size gondola top. Specify dimensions when placing order.</p> <p>SHB012</p>
	<p>Gondola Center Stem Base</p> <p>For use with stem signage on gondola tops. Custom formed to fit any size. Specify dimensions when placing order.</p> <p>SHB014</p>

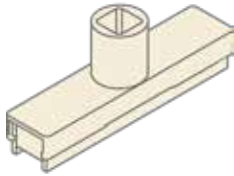

Magnetic Stem Base

Strong magnetic grip for use with metal shelving, racks and cabinets. Match the colour to the frame. Available in clear and standard colours.

SHB011

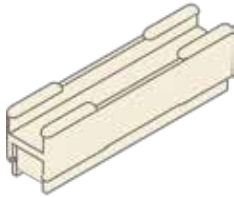

Parallel Magnetic Base

Strong magnetic grip for use with metal shelving, racks and cabinets. Match the colour to the frame. Available in clear and standard colours.

SHB027

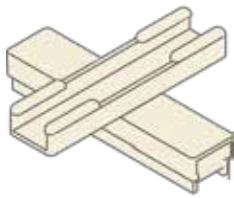

Magnetic Base-Cross

Strong magnetic grip for use with metal shelving, racks and cabinets. Match the colour to the frame. Available in clear and standard colours.

SHB028



Universal Mount

For mounting to square and round tubing from 1" to 1½". Solid steel with chrome finish.

SHA025



Universal Hang-Rod Clamp

Perfect for apparel and rack signing. Fits square, round and rectangular rods. Available in clear plastic.

1½" x 2¾" x 1"

SHA026



Wall Mount Clip

Easily attaches frames to flat surfaces.

SHA022



Suction Cup Mount

Mounts on glass and smooth surfaces.

SHA024

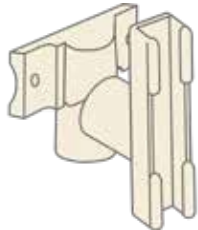

Self-Centering Pegboard / Slatwall Mount

Attaches a frame to a flat or solid surface. Mounting hardware available.

SHA035

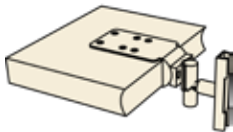

Shelf Top Centering Swivel Mount

Attaches to most shelf edges.

SHA032

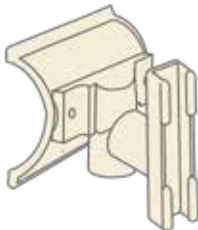

Self-Centering C-Channel Mount

Attaches a frame to a front C-Channel.

SHA033

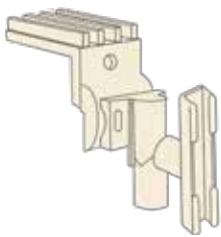

Self-Centering Under Shelf Swivel Mount

Attaches under the shelf and holds frame perpendicular to shelf edge.

SHA034

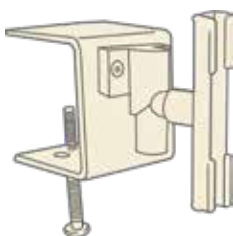





Metal Self-Centering Mount

Attaches and self-centers most signage to any shelf. Custom colours available (minimum order required).

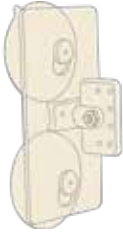
SHA037

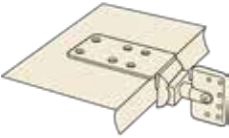

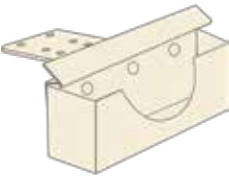
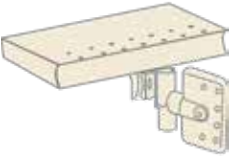
	<h3>Suction Cup Locking Sign Clip</h3> <p>Attaches display signage to glass or smooth surfaces. Signage is held in place with a clip.</p> <p style="text-align: right;">SHC220</p>	
	<h3>Shelf Locking Sign Clip</h3> <p>Attaches display signage above or under a shelf. Signage securely held in place with a clip.</p> <p style="text-align: right;">SHC210</p>	
	<h3>Shelf Bin Holder</h3> <p>Attaches a bin above or below a shelf. The bin is securely held in place with a clip.</p> <p style="text-align: right;">ACCSH0010</p>	
	<h3>Shelf Spring Sign Clip</h3> <p>Attaches display signage above or under a shelf. Signage securely held in place with a clip that returns it to the correct position if accidentally bumped.</p> <p style="text-align: right;">SHC212</p>	

Popular Sign Holder Kits

These sign holder kits are some of our most frequently requested configurations. Kits are based on 4" stem lengths where applicable.

	<h3>Sign Frame with Adjustable Telescopic Pole & Base</h3> <p>Frames available in beige, black, red and white. Graphic area varies according to frame size. Stem Mount base (included) Adjustable Telescopic Pole: 12" - 24"H Also Available with 2", 6", 8", 10" and 12" stem.</p> <table border="1" style="width: 100%;"> <tr> <td>3½" x 5½"</td> <td>PS172-355</td> </tr> <tr> <td>5½" x 7"</td> <td>PS172-557</td> </tr> <tr> <td>5" x 6"</td> <td>PS172-056</td> </tr> <tr> <td>7" x 11"</td> <td>PS172-711</td> </tr> <tr> <td>8½" x 11"</td> <td>PS172-085</td> </tr> <tr> <td>11" x 14"</td> <td>PS172-114</td> </tr> </table>	3½" x 5½"	PS172-355	5½" x 7"	PS172-557	5" x 6"	PS172-056	7" x 11"	PS172-711	8½" x 11"	PS172-085	11" x 14"	PS172-114
3½" x 5½"	PS172-355												
5½" x 7"	PS172-557												
5" x 6"	PS172-056												
7" x 11"	PS172-711												
8½" x 11"	PS172-085												
11" x 14"	PS172-114												

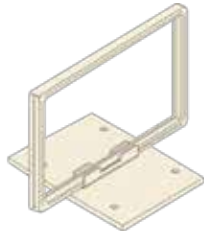

Sign Frame with Flat Base

Frames available in beige, black, red and white

3½" x 5½"	PS002-355
5½" x 7"	PS002-557
5" x 6"	PS002-056
7" x 11"	PS002-711
8½" x 11"	PS002-085
11" x 14"	PS002-114

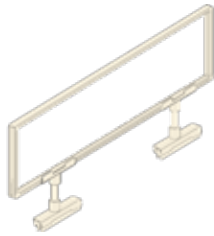

Sign Frame with Two Magnetic Stem Bases

Includes Stem Mount. Frames available in black and white.

5½" x 24"	PS176-524
5½" x 36"	PS176-536

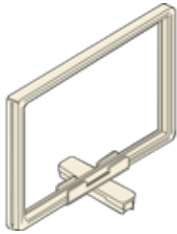

Sign Frame with Magnetic Base

Frames available in beige, black, red and white.

3½" x 5½"	PS115-355
5½" x 7"	PS115-557
5" x 6"	PS115-056
7" x 11"	PS115-711
8½" x 11"	PS115-085
11" x 14"	PS115-114

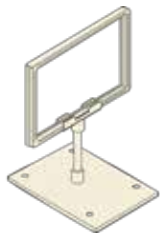

Sign Frame with Centre Stem Base

Frames available in beige, black, red and white. Includes stem mount, available in 2", 6", 8", 10" and 12" lengths. Specify stem length and kit colour when ordering.

3½" x 5½"	PS004-355
5½" x 7"	PS004-557
5" x 6"	PS004-056
7" x 11"	PS004-711
8½" x 11"	PS004-085
11" x 14"	PS004-114

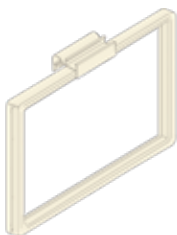

Sign Frame with Wire Bin Mount

Frames available in beige, black, red and white.

3½" x 5½"	PS127-355
5½" x 7"	PS127-557
5" x 6"	PS127-056
7" x 11"	PS127-711
8½" x 11"	PS127-085
11" x 14"	PS127-114

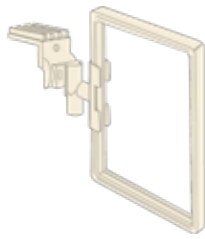

Sign Frame with Self-Centering Undershelf Mount

Frames available in beige, black, red and white. Includes stem mount.

3½" x 5½"	PS151-355
5½" x 7"	PS151-557
5" x 6"	PS151-056
7" x 11"	PS151-711
8½" x 11"	PS151-085
11" x 14"	PS151-114

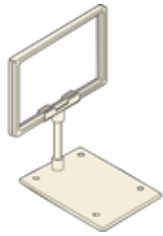

Sign Frame with Shovel Base

Frames available in beige, black, red and white. Stem mount included, available in 2", 6", 8" 10" and 12" lengths.

3½" x 5½"	PS010-355
5½" x 7"	PS010-557
5" x 6"	PS010-056
7" x 11"	PS010-711
8½" x 11"	PS010-085
11" x 14"	PS010-114



Sign Frame with Self-Centering Undershelf Swivel Mount

Includes Stem Mount. Frames available in beige, black, red and white.

5½" x 24"	PS175-524
5½" x 36"	PS175-536

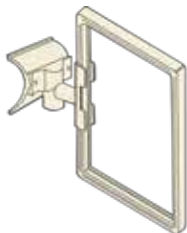

Sign Frame with Self-Centering C-Channel Mount

Frames available in beige, black, red and white. Includes stem mount.

3½" x 5½"	PS145-355
5½" x 7"	PS145-557
5" x 6"	PS145-056
7" x 11"	PS145-711
8½" x 11"	PS145-085
11" x 14"	PS145-114

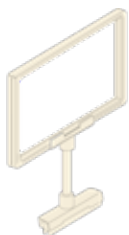

Sign Frame with Magnetic Stem Base

Frames available in beige, black, red and white. Included stem available in 2", 6", 8" 10" and 12" lengths.

3½" x 5½"	PS134-355
5½" x 7"	PS134-557
5" x 6"	PS134-056
7" x 11"	PS134-711
8½" x 11"	PS134-085
11" x 14"	PS134-114

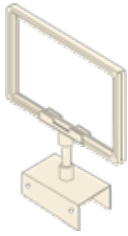

Sign Frame with Gondola Stem Base

Frames available in beige, black, red and white. Included stem available in 2", 6", 8" 10" and 12" lengths.

3½" x 5½"	PS140-355
5½" x 7"	PS140-557
5" x 6"	PS140-056
7" x 11"	PS140-711
8½" x 11"	PS140-085
11" x 14"	PS140-114

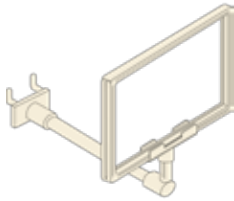

Sign Frame with Pegboard Extension Mount

Also available with 2", 6", 8" 10" and 12" stem. Specify stem length and kit colour when ordering.

3½" x 5½"	PS158-355
5½" x 7"	PS158-557
5" x 6"	PS158-056
7" x 11"	PS158-711
8½" x 11"	PS158-085
11" x 14"	PS158-114

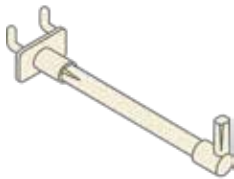

Pegboard / Slatwall Extension Mount

Available in seven standard lengths.

2" Stem	SHA102
4" Stem	SHA104
6" Stem	SHA106
8" Stem	SHA108
10" Stem	SHA110
12" Stem	SHA112
15" Stem	SHA115

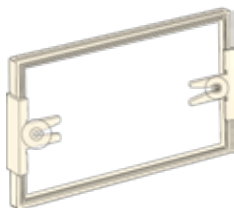

Sign Frame with Suction Cup

Includes two suction cups. Available in beige, black, red and white.

3½" x 5½"	PS170-355
5½" x 7"	PS170-557
5" x 6"	PS170-056
7" x 11"	PS170-711
8½" x 11"	PS170-085
11" x 14"	PS170-114

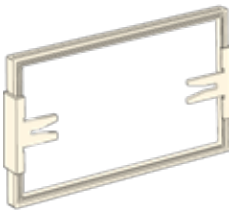

Sign Frame with Wall Mount

Includes two wall mounts. Available in beige, black, red and white.

3½" x 5½"	PS171-355
5½" x 7"	PS171-557
5" x 6"	PS171-056
7" x 11"	PS171-711
8½" x 11"	PS171-085
11" x 14"	PS171-114

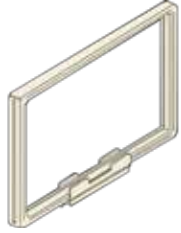

Sign Frame with Parallel Magnetic Stem Base

Frames available in beige, black, red and white.

3½" x 5½"	PS121-355
5½" x 7"	PS121-557
5" x 6"	PS121-056
7" x 11"	PS121-711
8½" x 11"	PS121-085
11" x 14"	PS121-114

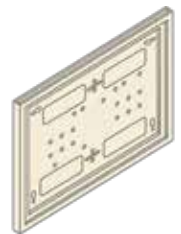

Shopping Cart/Wall Mount Sign Holder



Weather resistant sign holder mounts to shopping cart or wall to display store messaging or advertising.

Standard Kit Includes:

- 2 - Frames
- 2 - Clear Vinyl Foldovers
- 2 - Permanent Locking Straps

Available in black, red, silver or white. Custom colours available (minimum order required).

7"H x 11"W	CARTKIT711
8½"H x 11"W	CARTKIT8511

Floor Standing Sign Holders

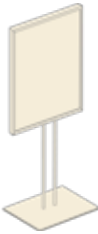

Standing Bulletin Sign with Flat Base

Graphic Area: 28"H x 22"W
Overall Height: 60"
Specify frame colour when placing order.

Chrome	FSD020
Black	FSD020BK



Standing Bulletin Sign with Trumpet Base

28"H x 22"W Graphic area
15" Trumpet base
60" Overall height

Chrome	FSD020TRUMPET
Black	FSD020TRUMPETBK



Three-Way Floor Standing Sign Holder

Graphic Area varies according to frame size.
6" Chrome Base
Adjustable Telescopic Pole: 24" - 48"H
Frames available in beige, black, red and white.

3½" x 5"	FSD035
5½" x 7"	FSD036
7" x 11"	FSD025
8½" x 11"	FSD032
11" x 14"	FSD034



Three-Way Pillar Floor Standing Sign

Frames available in beige, black, red and white.
Graphic Area varies according to frame size.
8" Chrome Base
36" - 72"H Adjustable Telescopic Pole

24"H x 5½"W	FSD029
36"H x 5½"W	FSD030



Floor Standing Sign Holder

Frames available in beige, black, red and white.
Graphic Area varies according to frame size.
6" Chrome Base
24" - 48"H Adjustable Telescopic Pole

3½" x 5½"	FSD040
3¼" x 8¼"	FSD041
5" x 6"	FSD042
5½" x 7"	FSD043
7" x 11"	FSD026
8½" x 11"	FSD044
11" x 14"	FSD045



Wobbler Floor Standing Sign Holder

6" Chrome Base
24" - 48"H Adjustable Telescopic Pole

Black Stem	FSD027BK
Clear Stem	FSD027CL
Red Stem	FSD027RD
White Stem	FSD027WT



Sidewalk A-Frame

Metal sidewalk frame with weighted bottom.
32"H X 19½"W

Black	PSTAFR
-------	--------



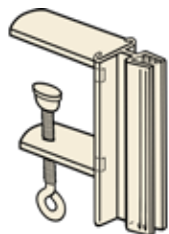

Aisle Sign Holder with C-Clamp

Add flag aisle signage up to 1½” thick for square-edge shelves or other fixtures. Holds signage up to 10 pt thick. Sign holder is 3” long.

SHC008SM

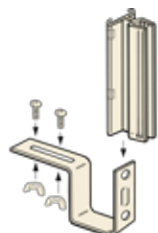

Under-Shelf Mount Sign Holder

Fits most perforated shelves using the included bolts and wing nuts. 3” long with a 10 pt capacity and made of beige metal and clear PVC.

SHA091BEIGECLR

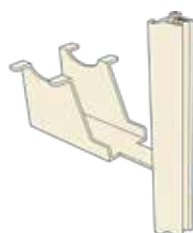

Under-Shelf Mount SuperGrip® Sign Holder

Steel spring tabs fit most perforated shelves. Holds signs up to 010 pt thick. Use two holders to support blade signs from shelf to shelf.

SHA039

NEW

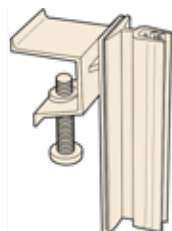

Channel Mount Gripper Sign Holder

Gripper fins hold signs firmly in vertical (flag) position. Use two or more holders from shelf to shelf for larger signs. Hinged style option is great for mounting signs in high traffic areas - flexible hinge swings and returns to original position when bumped. Base is designed to fit into most standard 1¼” shelf price channels with the turn of an attached Phillips/slotted combo pan head screw. Grippers are 3” long x ¾” wide base. Small capacity grippers have ¾” height; large capacity grippers have 1” height. Grippers are made of clear PVC material. Integrated adhesive/glue attached base. Also available with thumb screw. Base is made of beige ABS material.

SH0008

NEW

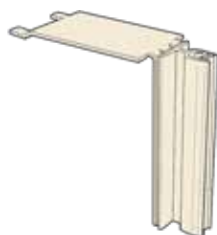

Shelf Mount Gripper Sign Holder - Metal

Gripper fins hold signs firmly in vertical (flag) position. Use two or more holders from shelf to shelf for larger signs. Hinged style option is great for mounting signs in high traffic areas. Metal base is designed for extra strength and durability and fits into most perforated shelves. Grippers are 3” long x ¾” wide base. Small capacity grippers have ¾” height; large capacity grippers have 1” height. Grippers are made of clear PVC material. Integrated adhesive/glue attached base. Base is made of beige painted steel material.

SH0009

NEW

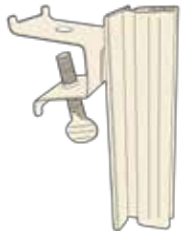

Channel Mount Gripper Sign Holder - Metal

Gripper fins hold signs firmly in vertical (flag) position. Use two or more holders from shelf to shelf for larger signs. Metal base is designed for extra strength and durability and fits into most standard 1-1/4" shelf price channels with the turn of an attached thumb screw.

Grippers are 3" long x 3/4" wide base

Small capacity grippers have 3/4" height; large capacity grippers have 1" height

Grippers are made of clear PVC material

Integrated adhesive/glue attached base

Base is made of beige painted spring steel material.

SH0007

NEW

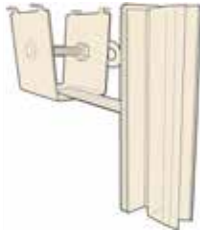

Under-Shelf Screw-Mount Gripper Sign Holder

Gripper fins hold signs firmly in vertical (flag) position. Use two or more holders from shelf to shelf for larger signs. Hinged style option is great for mounting signs in high traffic areas. Base locks underneath shelf with an integrated threaded eye screw and is designed to add shelf edge signs from below. Spring steel leg tabs clip directly into most perforated shelves.

Grippers are 3" long x 3/4" wide base

Small capacity grippers have 3/4" height; large capacity grippers have 1" height

Grippers are made of clear PVC material

Integrated adhesive/glue attached base

Base is made of beige painted spring steel material

Assembled eye screw is 10-24 x 2 1/4" overall length, zinc plated steel

SH0006

NEW



Magnetic Under-Shelf Sign Holder with Gripper

Gripper fins hold signs firmly in vertical (flag) position. Use two or more holders from shelf to shelf for larger signs. The magnetic base mounts underneath shelf and is designed to add shelf edge signs from below. Integrated, heavy duty magnet attaches to any metal surface, including the underside of perforated shelves.

Grippers are 3" long x 3/4" wide base

Small capacity grippers have 3/4" height; large capacity grippers have 1" height

Grippers are made of clear PVC material

Integrated adhesive/glue attached base

Base is made of beige ABS material

SH0005M-F

NEW



Magnetic Under-Shelf Sign Holder with Hinge

Gripper fins hold signs firmly in horizontal position. The magnetic base mounts underneath the shelf and is designed to attach shelf edge signs from. The heavy duty magnet attaches to any metal surface, including the underside of perforated shelves.

Small capacity grippers have 3/4" height; large capacity grippers have 1" height

Grippers are made of clear PVC material

Base is made of beige ABS Material

Integrated adhesive/glue attached base

SH0005M

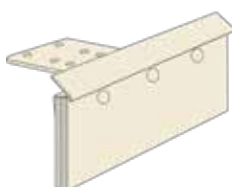

Coupon Holder

Attaches coupon books above or below shelves.

ACCSH0020

Coil Mounts

The Easiest Way to Attach Signage to Any Shelf. Moulded in clear polycarbonate. Custom colours also available (minimum order required).



How It Works: Spring Coil Mount

When it comes to displaying in-store signage, Coil Mounts give you unparalleled flexibility. The coil stretches to accommodate shelves up to several inches thick and reuse it as often as you'd like. Also, it won't scratch surfaces so it's perfect for wood and delicate surfaces.



Great Flexibility



Spring Coil with Card Clip

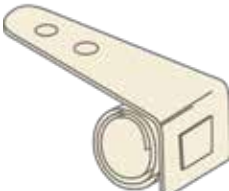
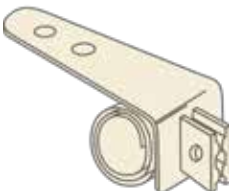
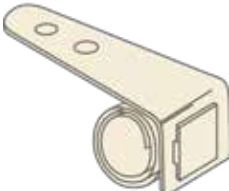
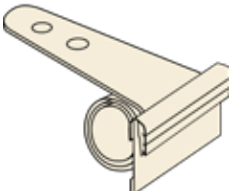

Spring Coil with Extrusion Adapter

	<p>Clear Spring Coil</p> <p>Holds labels, coupons and Pocket Sign Holders. Available with or without double sided tape. Moulded in durable, clear polycarbonate.</p> <p style="text-align: right;">SHA060</p>
	<p>Spring Coil with Card Clip</p> <p>Holds small signs and cards 10 pt. to 30pt. in thickness. Moulded in durable, clear polycarbonate.</p> <p style="text-align: right;">SHA061</p>
	<p>Spring Coil with Extrusion Adapter</p> <p>Attaches to an extruded sign holder so signs can be easily inserted and removed. Sign holders are moulded in durable clear polycarbonate and made to custom specifications.</p> <p style="text-align: right;">SHA062</p>
	<p>Spring Coil Mount with Griper Applied</p> <p>Holds paper or plastic signs. Moulded in durable, clear polycarbonate.</p> <p style="text-align: right;">SHA064</p>

Clear Sign Holder Solutions

How It Works: Clear Sign Holders

Our Clear Sign Holder solutions provide an effective way to advertise your new products, sales or services on tables, countertops and shelves.

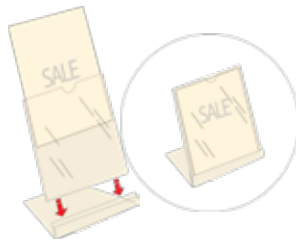
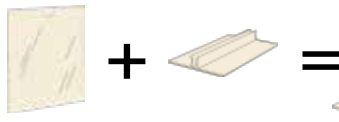

Clear Sign Holder with
Clear Angled Base Holder

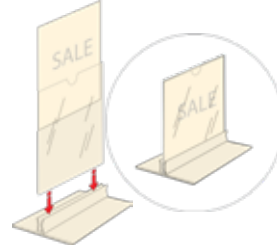

Clear Sign Holder with
Clear T-Base Holder



Clear Sign Holder

Can be used with adhesives or base holders. Equipped with stoppers that prevent cards from slipping out when used horizontally or vertically.

2" x 6"	SH026CLEAR
4" x 6"	SH046CLEAR
5½" x 7"	SH0557CLEAR
8½" x 11" (Sign Holder comes with thumb notch for easy graphic removal)	SH08511CLEAR



Clear Angle Base Holder

Co-Poly extruded base, 2¼" deep. Cut to required length to fit clear sign holders.

SHC055CLEAR



Clear T-Base Holder

Co-Poly extruded T-base. Cut to required length to fit clear sign holders.



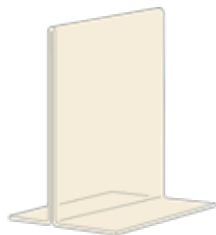

SHE3094CLEAR



Clear Inverted T-Sign Holder



Custom sizes available.

3½"H x 5½"W	INVT3555
5½"H x 7"W	INVT0557
7"H x 11"W	INVT0711
8½"H x 11"W	INVT8511

	<h3>Clear L-Angled Sign Holder</h3> <p>Custom sizes available.</p> <table border="1"> <tr> <td>3½"H x 5½"W</td> <td>LSH3555</td> </tr> <tr> <td>5½"H x 7"W</td> <td>LSH0557</td> </tr> <tr> <td>7"H x 11"W</td> <td>LSH0711</td> </tr> <tr> <td>8½"H x 11"W</td> <td>LSH8511</td> </tr> </table>	3½"H x 5½"W	LSH3555	5½"H x 7"W	LSH0557	7"H x 11"W	LSH0711	8½"H x 11"W	LSH8511
3½"H x 5½"W	LSH3555								
5½"H x 7"W	LSH0557								
7"H x 11"W	LSH0711								
8½"H x 11"W	LSH8511								
	<h3>Clear Tent-Shaped Sign Holder</h3> <p>Custom sizes available.</p> <table border="1"> <tr> <td>3½"H x 5½"W</td> <td>TESH0001</td> </tr> <tr> <td>5½"H x 7"W</td> <td>TESH0002</td> </tr> </table>	3½"H x 5½"W	TESH0001	5½"H x 7"W	TESH0002				
3½"H x 5½"W	TESH0001								
5½"H x 7"W	TESH0002								
	<h3>Clear Top Mount Sign Holder</h3> <p>Custom sizes available.</p> <table border="1"> <tr> <td>3"H x 5"W</td> <td>TOP0053</td> </tr> </table>	3"H x 5"W	TOP0053						
3"H x 5"W	TOP0053								
	<h3>Clear Slatwall Foldover Sign Holder</h3> <p>Custom sizes available.</p> <table border="1"> <tr> <td>5½"H x 3½"W</td> <td>SLF03555</td> </tr> <tr> <td>7"H x 5½"W</td> <td>SLF00557</td> </tr> <tr> <td>11"H x 7"W</td> <td>SLF00711</td> </tr> <tr> <td>11"H x 8½"W</td> <td>SLF08511</td> </tr> </table>	5½"H x 3½"W	SLF03555	7"H x 5½"W	SLF00557	11"H x 7"W	SLF00711	11"H x 8½"W	SLF08511
5½"H x 3½"W	SLF03555								
7"H x 5½"W	SLF00557								
11"H x 7"W	SLF00711								
11"H x 8½"W	SLF08511								
	<h3>Clear T-Shaped Sign Holder</h3> <p>Display signs on countertop, shelf or table. Graphic loads from top. Made of clear styrene.</p> <table border="1"> <tr> <td>4" x 6"</td> <td>CLSIG205</td> </tr> <tr> <td>8½" x 11"</td> <td>CLSIG200</td> </tr> </table> 	4" x 6"	CLSIG205	8½" x 11"	CLSIG200				
4" x 6"	CLSIG205								
8½" x 11"	CLSIG200								
	<h3>Clear L-Shaped Sign Holder</h3> <p>Display signage on countertops, shelves or tables. Graphic loads from top and L-shape allows sign to be viewed at an upward-facing angle. Custom sizes available.</p> <table border="1"> <tr> <td>4" x 6"</td> <td>CLSIG215</td> </tr> <tr> <td>5" x 7"</td> <td>CLSIG220</td> </tr> <tr> <td>8½" x 11"</td> <td>CLSIG225</td> </tr> </table>	4" x 6"	CLSIG215	5" x 7"	CLSIG220	8½" x 11"	CLSIG225		
4" x 6"	CLSIG215								
5" x 7"	CLSIG220								
8½" x 11"	CLSIG225								

	<p>Clear Y-Shaped Sign Holder</p> <p>Custom sizes available.</p> <table border="1"> <tr> <td>4H" x 6W" (Engraveable Area : 1½"H x 4"W)</td> <td>CLSIG210</td> </tr> </table>	4H" x 6W" (Engraveable Area : 1½"H x 4"W)	CLSIG210		
4H" x 6W" (Engraveable Area : 1½"H x 4"W)	CLSIG210				
	<p>Clear Sign Holder with Metal Base</p> <p>Chrome Finish.</p> <table border="1"> <tr> <td>5½"H x 7"W</td> <td>SH0755CRB</td> </tr> <tr> <td>7"H x 11"W</td> <td>SH0117CRB</td> </tr> </table>	5½"H x 7"W	SH0755CRB	7"H x 11"W	SH0117CRB
5½"H x 7"W	SH0755CRB				
7"H x 11"W	SH0117CRB				
	<p>Metal Sign Holder with Shovel Base</p> <p>Chrome Finish.</p> <table border="1"> <tr> <td>5½"H x 7"W</td> <td>SH0755CSB</td> </tr> <tr> <td>7"H x 11"W</td> <td>SH0117CSB</td> </tr> </table>	5½"H x 7"W	SH0755CSB	7"H x 11"W	SH0117CSB
5½"H x 7"W	SH0755CSB				
7"H x 11"W	SH0117CSB				
	<p>Metal Sign Holder</p> <p>Chrome Finish.</p> <table border="1"> <tr> <td>5½"H x 7"W</td> <td>SH0755CS</td> </tr> <tr> <td>7"H x 11"W</td> <td>SH0117CS</td> </tr> </table>	5½"H x 7"W	SH0755CS	7"H x 11"W	SH0117CS
5½"H x 7"W	SH0755CS				
7"H x 11"W	SH0117CS				
	<p>Metal Threaded Swege Stem</p> <p>Chrome Finish.</p> <table border="1"> <tr> <td>3"</td> <td>SHA300B</td> </tr> <tr> <td>6"</td> <td>SHA600B</td> </tr> </table>	3"	SHA300B	6"	SHA600B
3"	SHA300B				
6"	SHA600B				
	<p>Metal Threaded Stem</p> <p>Chrome Finish.</p> <table border="1"> <tr> <td>3"</td> <td>SHA300A</td> </tr> <tr> <td>6"</td> <td>SHA600A</td> </tr> </table>	3"	SHA300A	6"	SHA600A
3"	SHA300A				
6"	SHA600A				

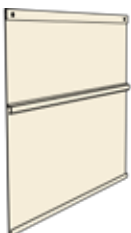
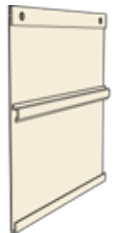
Hanging Boards

	<h3>Spiral Sign Holder</h3> <p>Sign holder attaches permanently to flat surfaces and its side-accessibility allows for quick sign changeovers.</p> <table border="1"> <tr> <td>Single sided</td> <td></td> <td>SHE00010</td> </tr> </table>	Single sided		SHE00010									
Single sided		SHE00010											
	<h3>Small Hanging Boards</h3> <p>Top section fits a 4" message card and the bottom section fits 6" flip number cards. 10¾" overall height. Available as single or double sided.</p> <table border="1"> <tr> <td>Single sided</td> <td>Black</td> <td>SHE0782BLACK</td> </tr> <tr> <td>Single sided</td> <td>White</td> <td>SHE0782WHITE</td> </tr> <tr> <td>Double sided</td> <td>Black</td> <td>SHE0782DBLACK</td> </tr> <tr> <td>Double sided</td> <td>White</td> <td>SHE0782DWHITE</td> </tr> </table>	Single sided	Black	SHE0782BLACK	Single sided	White	SHE0782WHITE	Double sided	Black	SHE0782DBLACK	Double sided	White	SHE0782DWHITE
Single sided	Black	SHE0782BLACK											
Single sided	White	SHE0782WHITE											
Double sided	Black	SHE0782DBLACK											
Double sided	White	SHE0782DWHITE											
	<h3>Large Hanging Boards</h3> <p>Top section fits a 6¼" message card and the bottom section fits 11" flip number cards. 19" overall height. Available as single or double sided.</p> <table border="1"> <tr> <td>Single sided</td> <td>Black</td> <td>SHB703BLACK</td> </tr> <tr> <td>Single sided</td> <td>White</td> <td>SHB703WHITE</td> </tr> <tr> <td>Double sided</td> <td>Black</td> <td>SHB703DBLACK</td> </tr> <tr> <td>Double sided</td> <td>White</td> <td>SHB703DWHITE</td> </tr> </table>	Single sided	Black	SHB703BLACK	Single sided	White	SHB703WHITE	Double sided	Black	SHB703DBLACK	Double sided	White	SHB703DWHITE
Single sided	Black	SHB703BLACK											
Single sided	White	SHB703WHITE											
Double sided	Black	SHB703DBLACK											
Double sided	White	SHB703DWHITE											
	<h3>Small Flip Number Set</h3> <table border="1"> <tr> <td>3⅝" H x 2" W</td> <td>Numeral / \$ Pads</td> <td>HBSM0010</td> </tr> <tr> <td>3⅝" H x 1⅜" W</td> <td>Numeral / ¢ Pads</td> <td>HBSM0020</td> </tr> <tr> <td>3⅝" H x 1⅜" W</td> <td>Reader Pads</td> <td>HBSM0030</td> </tr> </table>	3⅝" H x 2" W	Numeral / \$ Pads	HBSM0010	3⅝" H x 1⅜" W	Numeral / ¢ Pads	HBSM0020	3⅝" H x 1⅜" W	Reader Pads	HBSM0030			
3⅝" H x 2" W	Numeral / \$ Pads	HBSM0010											
3⅝" H x 1⅜" W	Numeral / ¢ Pads	HBSM0020											
3⅝" H x 1⅜" W	Reader Pads	HBSM0030											
	<h3>Large Flip Number Set</h3> <table border="1"> <tr> <td>11⅝" H x 5⅜" W</td> <td>Numeral / \$ Pads</td> <td>HBLG0010</td> </tr> <tr> <td>11⅝" H x 3" W</td> <td>Numeral / ¢ Pads</td> <td>HBLG0020</td> </tr> <tr> <td>11⅝" H x 3" W</td> <td>Reader Pads</td> <td>HBLG0030</td> </tr> </table>	11⅝" H x 5⅜" W	Numeral / \$ Pads	HBLG0010	11⅝" H x 3" W	Numeral / ¢ Pads	HBLG0020	11⅝" H x 3" W	Reader Pads	HBLG0030			
11⅝" H x 5⅜" W	Numeral / \$ Pads	HBLG0010											
11⅝" H x 3" W	Numeral / ¢ Pads	HBLG0020											
11⅝" H x 3" W	Reader Pads	HBLG0030											

Aisle Markers

Get these silent salespeople working for you! Double-sided for twice the exposure. Injection moulded corners are twin-pronged for maximum stability. Quality mitre-edge finish. Use our mounting accessories to hold your signs on slatwall, pegboard or a shelf. Aisle Markers are even great gondola toppers. Available in white, black, red and beige. Custom colours and lengths are also available (minimum order required).



How It Works: Aisle Markers with Mounting Accessories

Slide your signs into both sides of the extruded frame wall. Secure them in place with top, bottom and twin-pronged corners. Display it vertically or horizontally with our mounting accessories. Use with our Self-Centering Mounts and your Aisle Marker will bounce back if bumped.

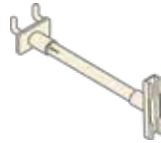
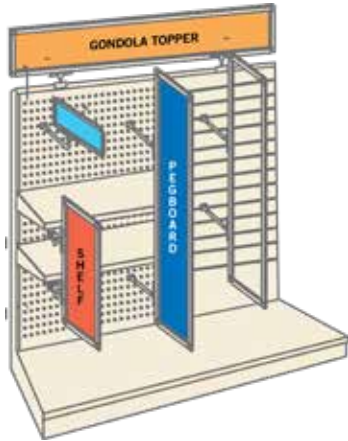

SHA116WHITE10
Pegboard/Slatwall
Extension Mount



SHA033
Self-Centreing
C-Channel Mount



SHB014
Gondola Centre
Stem Base

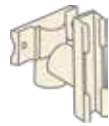

SHA035
Self-Centreing
Wall/Post Mount



SHA034
Self-Centreing Under
Shelf Swivel Mount

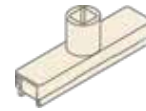

SHB011
Magnetic
Stem Base



One Piece Moulded Aisle Marker

Moulded in sturdy, high impact styrene. Available in black, white and custom colours (minimum order required)

5½" x 24"

SHOMMF5524

5½" x 36"

SHOMMF5536

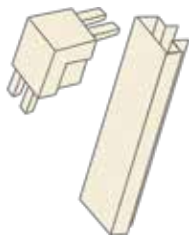

Custom Frames (Corners and Edging)

Corners and side pieces for building frames. Custom sizes available.

Custom Frame Edging

CFR001

Custom Frame Corners

CFR002

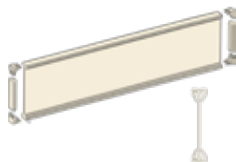

Aisle Marker

Aisle marker with rigid banner support. Frames available in beige, black, red and white. Available in different sizes.

3½" x 48" (29mm x 1219mm)

MMF348

5½" x 48" (140mm x 1219mm)

MMF548

How It Works: Dual Frame Mounting Accessories

Measure the length of your signage and send us with the length for the Dual Frame. Then choose the pegboard mounting accessory that works best for your application.

Select a Mounting Option



Attach two pieces of Dual Frame to signage

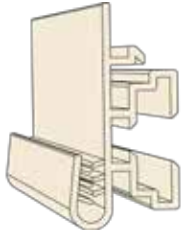
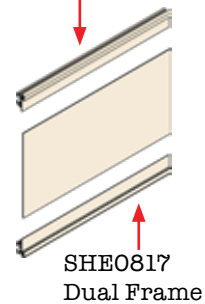

Dual Frame

Dual frame extrusion with gripper that fits 4pt. to 8pt. plastic. Can be hung using standard store hooks or stems and hooks.

1" - 96"L

SHE0817



Sign Riser

Upright Kit Includes:
2 - Pegboard/Slatwall Mounts
2 - Uprights

UPRO02



NEW



Shelf Top Sign Holder with Frame Holder

Mounts to standard gondola shelving. Frame holder compatible with our standard frame system. Made of durable ABS plastic. Comes in beige, white or black. Custom colours also available (minimum order required).

Shelf Top Sign Holder with
Frame holder

SHC139BK-FR



NEW



Shelf Top Sign Holder with Sign Gripper

Mounts to standard gondola shelving. Gripper holds 0.030" to 0.125" cardstock. Made of durable ABS plastic. Comes in beige, white or black. Custom colours also available (minimum order required).

Shelf Top Sign Holder with
Cardstock Gripper

SHC139BK-G



How It Works: Bracket Sign System

Make your own signs with these interchangeable brackets and sign holders, available in different colours and sizes. Use Gripper Mounts to create a flag-style sign. Use Frame-type sign holders can be used to create a more durable sign. Use Brackets to attach your sign to pegboard or uprights.

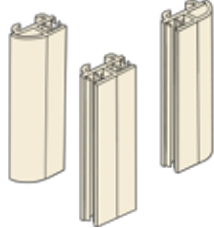
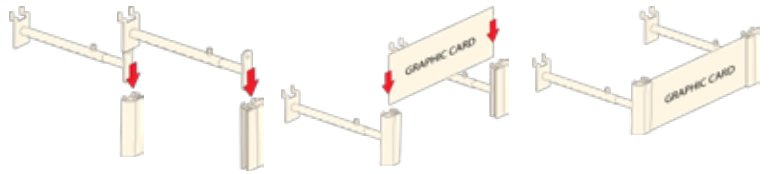

SuperGrip® Header Sign Holder

Accepts material thickness from 1/16" to 1/4".
Comes in 4" lengths. Available in clear, black or white.

Centre Sign Grip Holder

SIGN110

End Connector Sign Grip Holder

SIGN115



Clear Sign Frame Adapter

Works with the Bracket Sign System. Made of clear PVC.

3"

SIGN100



Clear Sign Frame Gripper

Hinged Gripper for the Bracket Sign System.

3"

SIGN105

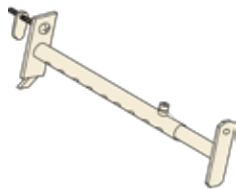

Gondola Upright Metal Telescopic Bracket

Compatible with sign holder adapters. Slides onto mounting plate with 1/16" capacity. Powder-coated in beige.

3"H x 3/4"W mounting area

TELGON100

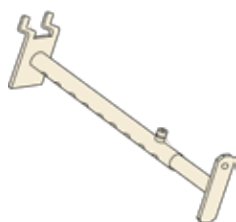

Pegboard Metal Telescopic Bracket

Compatible with sign holder adapters. Length is adjustable from 13"-21". Powder-coated in beige.

3"H x 3/4"W mounting area

TELPEG100

Card Clips



How It Works: Pivoting Sign Clip



Pivoting Sign Holder Bracket

Multi-Position Sign Gripper

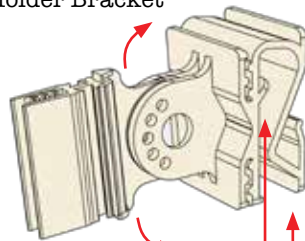

Slatwall Mounting Clip



C-Channel Mount



Slatwall and Wire Fence Mounting Clip

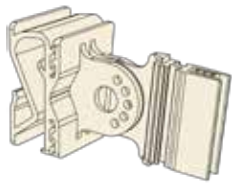

Pivoting Sign Clip

Versatile sign clip holder for graphic cards. Mounts directly to C-channel, slatwall, wire and shelf front channels (minimum order required).

SIGN210



How It Works: Perforated Card Clips

Card Clips make the ultimate shelf talkers. They hold cards parallel or perpendicular to the shelf with no adhesive or mounting hardware required! Holds cardstock 10pt. - 30 pt. .

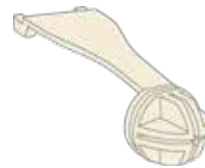

SHA070 Perforated Shelf Card Clip

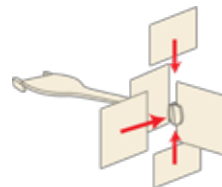

Perforated Shelf Card Clip

Attaches to perforated shelf and holds a card in 5 different ways. Holds material 10pt to 30pt.

US Patent #7515852

SHA070

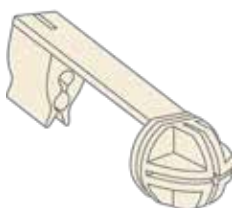

Wire / Peg Card Clip

Attaches to a peg, hook or wire bin and holds a card in 5 different ways. Holds material 10pt to 30pt.

US Patent #7515852

SHA071





Basket Clip

For use with wire bins. Holds labels size 1½" x 3". Available in clear and custom colours (minimum order required).

SHE2208CLEAR03

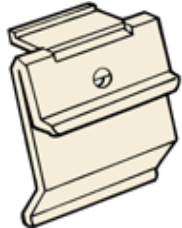

Fold-N-Hold Shelf Channel Flush Sign Holder

Punctures and holds signs securely. Fits most standard 1" shelves. Holds most paper signs up to 10pt. thick.

1¼"H x 1⅝" W

SHC042



Snap-It Sign Holder

Snaps onto a price channel and holds signs perpendicular to the shelf.

SHC045

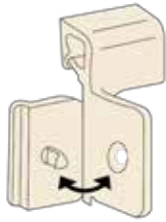

Clip-In Data Strip Fold N Hold

Hooks into a data strip to hold your advertising, up to 10pt. thick, at a 90° angle into the aisle. Made of natural polypropylene.

SIGN205



Clear Extruded Hinged Sign Holder

Securely holds signs at a 90° angle. Holds material up to 60pt. thick. Made of clear PVC.

SHT0613



Clear Extruded Sign Holder Clip

Moulded in clear PVC. Attaches to flat surfaces. Holds material up to 8pt. thick at a 90° angle.

SHT0612



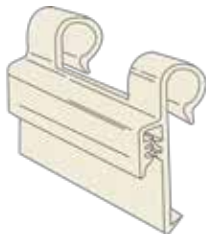

Clear Extruded Wire Basket Sign Holder

Attaches signs to wire up to $\frac{3}{8}$ " in diameter. Moulded in clear PVC.

$1\frac{3}{8}$ "W

SHT0619



Clear Extruded Wire Basket Card Clip

Attaches cards to wire up to $\frac{3}{8}$ " in diameter. Moulded in clear PVC.

$\frac{1}{2}$ "W

SHT0609



Double Duty Shelf Channel Sign Holder

Snaps onto a C-channel and displays price cards perpendicular to the shelf.

SHC046



SuperGrip® Flag C-Channel Card Holder

Securely holds signs in the flag position. Fits most standard $1\frac{1}{4}$ " shelf channels. Holds material up to 80pt. thick. Made of clear PVC.

$\frac{3}{4}$ "W

SHC047

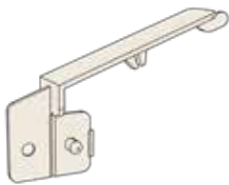

Fold-N-Hold Flag Sign Holder

For use with perforated shelves. Pierces signs to securely holds them in the flag position. Holds card stock up to 10pt. thick.

SHC041

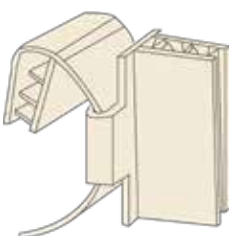

Adjustable Angle Sign Holder

Attaches sign to front of self. Facing angle is adjustable.

PX611

Sign Holder & Base Clips

Display information to your customers in a convenient way. These versatile card and label holders provide a clear view of your marketing material.

	<p>Clear Price Ticket Cube</p> <p>Clear acrylic cube accepts inserts from 20pt - 1/8". Slot holds cards at an angle. Perfect for price tickets in showcases.</p> <p>1 1/2"W x 1 1/2"L SHC026</p>	
	<p>Clear Grip Sign Holder</p> <p>Accepts inserts from 15pt - 1/8". Wider base and taller sides give better stability. Permanent adhesive on base.</p> <p>7/8"H x 1 1/8"W x 3"L SHE4485</p>	
	<p>Angled Card Holder</p> <p>1 1/4" x 1 3/4" Base SHC817</p> <p>2" x 2 1/2" Base SHC818</p>	
	<p>Clear Centre Mount Sign Holder</p> <p>Ribbed design holds paper signs secure. Holds paper signs up to 30pt. thick.</p> <p>1 7/8" x 1 3/4" SHC010</p>	
	<p>Memo Clip with Magnetic Base</p> <p>Memo clip with plastic countertop base.</p> <p style="text-align: right;">SHT1270</p>	



Clear Card Holder with Base

Adjust your sign to the angle of your shelf.

Plastic Base	SHT5241
Magnetic Base	SHT4701

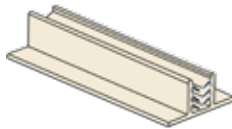

Small Base Clip

Small size is ideal for hard-to-sign areas. Gripper teeth accept material up to 1/16". Standard lengths available in 1" and 3" with 1/2" wide base. Custom lengths available.

1"	SHC030CLEAR01
3"	SHC030CLEAR03

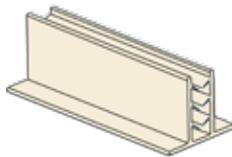

Large Base Clip

Ideal for foam board, Coroplast™ or corrugated signs. Accepts signs from 3/16" to 1/4" thick. Standard lengths in 3" and 6" with 1 1/2" wide base. Custom lengths available.

3"	SHC035CLEAR03
6"	SHC035CLEAR06

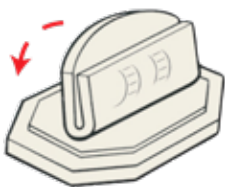

Clear Countertop Adjustable Sign Holder

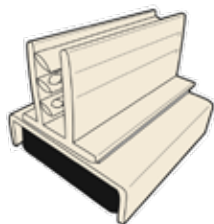

Tilts to view your sign from above or below. Holds material 8 pt. – 20 pt. thick.

SHT2021

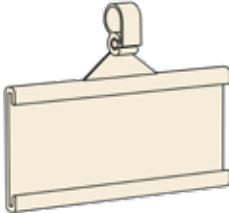
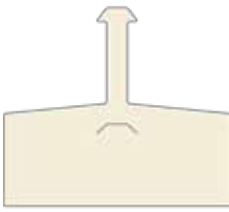
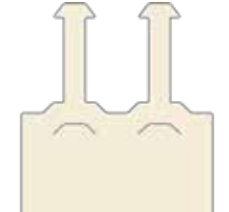

Magnetic Sign Holder with Gripper

1"W x 3/4"D	SHB030G
-------------	---------

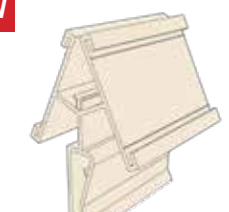
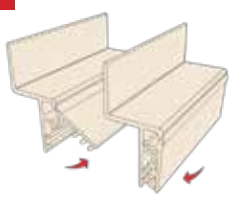
	<h3>Fold-N-Hold Ticket Holder</h3> <p>Natural polypropylene.</p> <table border="1"> <tbody> <tr> <td>1¼"H x 2"W</td> <td>HK056</td> </tr> <tr> <td>1¼"H x 3"W</td> <td>HK057</td> </tr> </tbody> </table>	1¼"H x 2"W	HK056	1¼"H x 3"W	HK057
1¼"H x 2"W	HK056				
1¼"H x 3"W	HK057				
	<h3>Wide UPC / Label Holder</h3> <p>Translucent white finish.</p> <table border="1"> <tbody> <tr> <td>1¼"H x 2¼"W</td> <td>HK051</td> </tr> <tr> <td>1¼"H x 3¾"W</td> <td>HK052</td> </tr> </tbody> </table>	1¼"H x 2¼"W	HK051	1¼"H x 3¾"W	HK052
1¼"H x 2¼"W	HK051				
1¼"H x 3¾"W	HK052				
	<h3>Double Loop UPC / Label Holder</h3> <p>Translucent white finish.</p> <table border="1"> <tbody> <tr> <td>1¼"H x 2½"W</td> <td>HK053</td> </tr> </tbody> </table>	1¼"H x 2½"W	HK053		
1¼"H x 2½"W	HK053				
	<h3>Fold-N-Hold Covered Ticket Holder</h3> <p>Hinged clasp fits up to ⅜" diameter wire. Easy load access.</p> <table border="1"> <tbody> <tr> <td>1¼"H x 2"W tickets</td> <td>HK050</td> </tr> </tbody> </table>	1¼"H x 2"W tickets	HK050		
1¼"H x 2"W tickets	HK050				
<p>NEW</p> 	<h3>Double Basket Clip</h3> <table border="1"> <tbody> <tr> <td>1"H x 1½"W x 9D"</td> <td>SHE4736</td> </tr> </tbody> </table>	1"H x 1½"W x 9D"	SHE4736		
1"H x 1½"W x 9D"	SHE4736				
<p>NEW</p> 	<h3>Z-Bar Slatwall Hanging Sign Gripper</h3> <p>Mount signage easily to slatwall. Hanging signage is a snap! Just snap the clear track right onto the edge of your sign. Available in custom lengths.</p> <table border="1"> <tbody> <tr> <td>46"L</td> <td>SHE0120CLEAR</td> </tr> </tbody> </table>	46"L	SHE0120CLEAR		
46"L	SHE0120CLEAR				



How It Works: Boot System with Poster Channel

The Boot System, coupled with a poster channel allows you to mount a poster or signage securely and quickly on top of standard retail gondolas.



SH09017BK
Magnetic Base



SH09017WHDTAPE
D-Tape Base

NEW

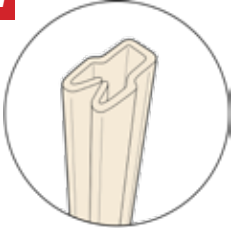

Boot System - Thin Poster Channel

Use with the Boot System Magnetic Base to securely hold signs from metal surfaces in either vertical or horizontal position. Made of clear PVC material.

5/8" H

SHE9404-18

NEW

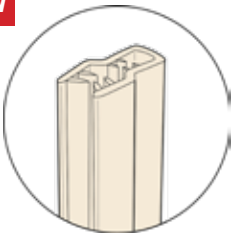

Boot System - Heavy Duty Gripper Poster Channel

Use with Boot System Magnetic Base to securely hold signs from metal surfaces in either vertical or horizontal position. Made of clear PVC material.

5/8" H

SHE9405-18

NEW

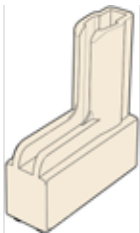

Boot System - Magnetic Base

A Sign holder system for displaying materials up to 1/4" thick on metal surfaces when coupled with a Thin Poster Channel or Heavy Duty Gripper Poster Channel. Boot shaped base is removable and can be re-positioned.

White

SH09017WH

Black

SH09017BK

NEW

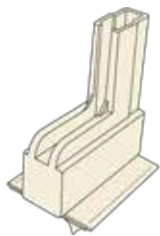

Boot System - D-Tape

A Sign holder system that, when coupled with our extruded Thin Poster Channel or Heavy-Duty Gripper Poster Channel, is capable of displaying materials up to 1/4" thick on nearly any clean, flat surface. Simply peel and stick for a secure, freestanding hold.

White

SH09017WHDTAPE

Black

SH09017BKDTAPE





Magnetic Header

15"H x 30"W

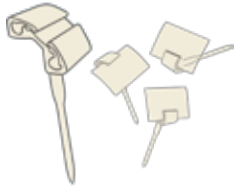
9109

	Price Spear		
	2" L	Clear	SHT0003
	2" L	White	SHT0003W

	Clear Plastic Pin with Memo Clip	
	2" L	SHT0105

	Clear Plastic Pin with Large Card Holder	
	2" L	SHT0405

Clip-Ons

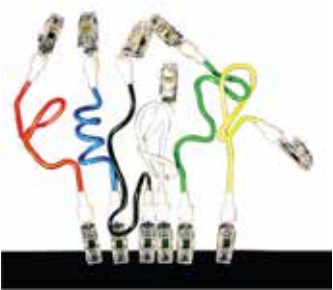
	Curly Wire Clips	
	Available in bold, bright colours, these 1/8" diameter wires are 12" long and can be bent to any shape you like. Attach a sign at each end or attach one end to your fixture. Available in white, black and a variety of fluorescent colours.	
	White	KK10W
	Black	KK10K
	Fluorescent Yellow	KK10Y-FLO
	Fluorescent Green	KK10G-FLO
	Fluorescent Blue	KK10B-FLO
	Fluorescent Orange	KK10O-FLO
	Fluorescent Pink	KK10P-FLO

	POP Sign Holder - Magnetic Base	
	Rod height: 2½" Round magnetic base: 5/8"	
	SHT0110	

NEW



POP Sign Holder - Square Base

Square base: 1¼" x 1¼"
 Rod height: 2½"
 Clip wide: ¼".

SHT0120

NEW



POP Sign Holder with T-Clip - Dome Base

T Clip
 Rod height: 2½"
 Dome base: 1 - ¼"

SHT0150

How It Works: Hot Pan Clip

Use our handy Hot Pan Clip to attach signs and cards to serving trays.
 Made of durable stainless steel.



SHT0125
 Hot Pan Clip

NEW



Hot Pan Clip

Made of stainless steel

2¾"W x 1½"D

SHT0125



Clip-On Adhesive Adapter for Wire

Wire clip on one side, adhesive pad on the other. White plastic. 1" total length.

KK011

	<p>Clip-On Adhesive Adapter</p> <p>Clip one end to a fixture and stick the other end to a sign or vice-versa. Tilts in any direction. 2¼" in length.</p> <p style="text-align: right;">KK012</p>
	<p>Double Clip-On Sign Holder</p> <p>Clips at either end hold material up to ¾" thick. Pivots in any direction. 3½" total length.</p> <p style="text-align: right;">KK013</p>
	<p>Clip-On Sign Holder</p> <p>Clip one end to a fixture and stick the other end to a sign, or vice-versa. Tilts in any direction. 2¼" in length.</p> <p style="text-align: right;">KK014</p>
	<p>Clip-On Sign Holder - 2"</p> <p>2" wide sign holder with clip on one end. Holds material 8 pt. - 20 pt. thick. Pivots in any direction. 4" total length.</p> <p style="text-align: right;">KK015</p>
	<p>Clip-On Spring Sign Holder</p> <p>3½" wide sign clip for material up to ¼" thick with extra-strong grip. Pivots in any direction. 4" total length.</p> <p style="text-align: right;">KK016</p>
	<p>Clip-On Extended Sign Holder</p> <p>2" wide sign holder with clip on the other end. Holds material 8 pt. - 20 pt. thick. Pivots from top and bottom in any direction</p> <p style="text-align: right;">6"L KK017</p>



Clip-On Extended Spring Sign Holder

3 1/8" wide sign clip for material up to 1/4" thick with extra-strong grip. Pivots from the top and bottom in any direction. 6 1/4" total length.

6 1/4"L

KK018



Clip-On Extended Sign Protector

Displays signs up to 1/32" thick with a protective clear cover. Pivots from the top and bottom in any direction. Clear cover available in two sizes.

3 1/2"H x 5 1/2"W

KK019A

5"H x 7"W

KK019B



Clip-On Wire Sign Holder

1" wide sign holder with 4" rigid wire in the middle and clip at base. Holds material 8 pt. - 20 pt. thick. Pivots from the top and bottom in any direction.

7 1/2"L

KK020



Magnetic Clip-On Sign Holder

Strong white magnetic base that attaches to most metal surfaces. Holds material up to 3/8" thick. Pivots from the top and bottom in any direction.

7"L

KK021



Suction Cup Clip-On Sign Holder

Suction cup base attaches to glass and other smooth surfaces. Holds material up to 3/8" thick. Pivots from the top and bottom in any direction.

6 1/2"L

KK022

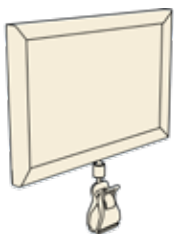

Clip-On Sign Protector

Display material 5 1/2"W x 3 1/4"H up to 1/32" thick. Clip grips material up to 1 1/8" thick.

KK023









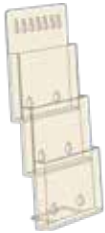

Brochure Holders & Acrylic Accessories

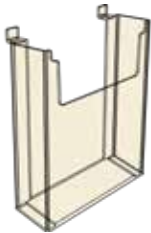
Display brochures and sales materials in any retail situation, with all the impact they deserve.

Brochure & Business Card Holders

Use every opportunity to make an impact and promote your product or service! Choose from a large selection of durable and affordable brochure holders. Our literature holders are perfect for displaying and organizing your pamphlets and sell sheets. Don't see what you're looking for? We'll design one for you!

	<p>Extended Pocket Brochure Holder</p> <p>Holds cards 5½”H x 4”W. Sits on counter or hangs on wall. Injection moulded. Hardware sold separately.</p> <p style="text-align: right;">BH0480</p>	
	<p>Magazine Pocket Holder</p> <p>Mounts to slatwall to display standard size 8½” x 11” magazines. Injection moulded.</p> <p>11”H x 8½”W BH0320</p>	
	<p>CD/Brochure Holder with Feet</p> <p>Holds CDs and brochures. Injection moulded.</p> <p>5¾”H x 5½”W BH0031F</p>	
	<p>CD/Brochure Holder</p> <p>Holds CDs and brochures. Injection moulded.</p> <p>5¾”H x 5½”W BH0030</p>	
	<p>Slant-Back Wall-Mounted Brochure Holder</p> <p>Wall-mounted slant-back brochure holder with mounting hole for screw. Injection moulded in clear styrene.</p> <p>7¾”H x 6¾”W BH0230</p>	

	<h3>Slant-Back Brochure Holder</h3> <p>Countertop slant-back brochure holder. Injection moulded in clear styrene.</p> <p>7¼”H x 4¼”W BH0220</p>
	<h3>Two Tier Slant-Back Brochure Holder</h3> <p>For brochures up to 8½” wide. Injection moulded in clear styrene.</p> <p>13¾”H x 8¾”W BH0460</p>
	<h3>Three Tier Slant-Back Brochure Holder</h3> <p>Slant back brochure holder with 3 compartments. Holds literature up to 8” wide. Injection moulded in clear styrene.</p> <p>13¾”H x 9¼”W BH0410</p>
	<h3>Four Tier Slant-Back Brochure Holder</h3> <p>Slant back brochure holder with 4 compartments. Can be used on a countertop or wall mounted. Injection moulded in clear styrene.</p> <p>10”H x 6⅞”W BH0430</p>
	<h3>Traditional Double Brochure Holder</h3> <p>For brochures up to 4½” wide. Injection moulded in clear styrene.</p> <p>8”H x 9⅝”W BH0440</p>
	<h3>Four Tier Double Brochure Holder</h3> <p>Slant back brochure holder with 8 compartments. Injection moulded in clear styrene.</p> <p>7¾”H x 8½”W BH0470</p>

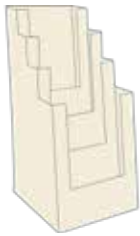

Four Tier Traditional Brochure Holder

Countertop slant back brochure holder with 4 compartments. Injection moulded in clear styrene.

10"H x 4¼"W

BH0400

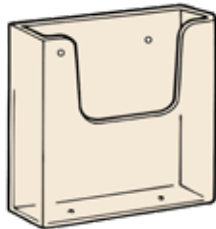

Wall Mount Brochure Holder

Holds brochures up to 6" wide. Easily mounts to a wall (hardware not included). Injection moulded in clear styrene.

6½"H x 6⅝"W x 1½" D

BH0920

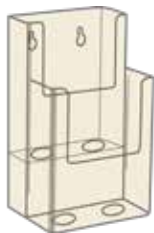

Two Tier Wall-Mounted Brochure Holder

For brochures up to 3¾" wide. Injection moulded in clear styrene.

6⅞" H x 4¼"W

BH0450



Traditional Wall-Mounted Brochure Holder

Wall mounted brochure holder with 1⅝" deep pocket capacity. Injection moulded in clear styrene.

7"H x 4⅛"W

BH0210



Wide Wall-Mounted Brochure Holder

Wall mounted brochure holder with 2" deep and 8½" wide pocket. Injection moulded in clear styrene.

9½"H x 8¾"W

BH0310

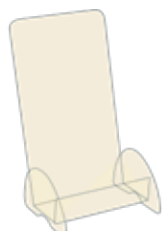



Euro-Style Green Edge Brochure Holder

Holds cards 8"H x 4"W. Injection moulded in clear styrene.

8"H x 4⅜"W

BH0510

	<h3>Card Holder</h3> <p>Attaches to any holder or frame. Injection moulded in clear styrene.</p>
	<p>1¼"H x 3¾"W x 2"D</p> <p style="text-align: right;">SHD006CLEAR</p>

	<h3>Single Business Card Holder</h3> <p>Countertop business card holder. Injection moulded in clear styrene.</p>
	<p>5¾"H x 5½"W</p> <p style="text-align: right;">BHO130</p>

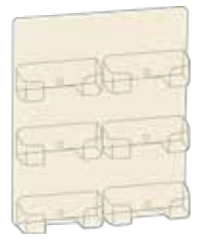
	<h3>Three Tier Double Wall-Mounted Business Card Holder</h3> <p>Wall-mounted business card holder with 6 compartments. Injection moulded in clear styrene.</p>
	<p style="text-align: right;">BHO150</p>

	<h3>Four Tier Double Business Card Holder</h3> <p>Countertop business card holder with 8 compartments. Injection moulded in clear styrene.</p>
	<p style="text-align: right;">BHO140</p>

Acrylic Accessories

When it comes to custom acrylic we can accommodate your every need. We pride ourselves on our custom design capabilities. Every stage from concept to manufacture is handled with care by our highly-qualified team of professionals. Let us help you with your next project.

	<h3>Slatwall/Pegboard Shelf</h3> <p>Made of clear acrylic. Custom sizes available.</p>
	<p>12"W x 6"D</p> <p style="text-align: right;">SLSH010ACR</p>

	<p>Slatwall Utility Shelf</p> <p>Injection moulded in clear plastic.</p> <table border="1"> <tr> <td>12"W x 6"D</td> <td></td> <td>SLSH020ACR</td> </tr> </table>	12"W x 6"D		SLSH020ACR			
12"W x 6"D		SLSH020ACR					
	<p>Slatwall Shoe Shelf</p> <p>Injection moulded in clear plastic.</p> <table border="1"> <tr> <td>10"W x 4"D</td> <td>Clear Acrylic</td> <td>SLSH030ACR</td> </tr> <tr> <td>10"W x 4"D</td> <td>Clear Styrene</td> <td>SLSH030STY</td> </tr> </table>	10"W x 4"D	Clear Acrylic	SLSH030ACR	10"W x 4"D	Clear Styrene	SLSH030STY
10"W x 4"D	Clear Acrylic	SLSH030ACR					
10"W x 4"D	Clear Styrene	SLSH030STY					
	<p>Slatwall Adjustable Shoe Shelf with Toe Stop</p> <p>Injection moulded in clear plastic.</p> <table border="1"> <tr> <td>Acrylic</td> <td></td> <td>SLSH040ACR</td> </tr> <tr> <td>Styrene</td> <td></td> <td>SLSH040ACR</td> </tr> </table>	Acrylic		SLSH040ACR	Styrene		SLSH040ACR
Acrylic		SLSH040ACR					
Styrene		SLSH040ACR					
	<p>Slatwall Magazine Holder with Spring Front</p> <p>Made of clear acrylic. Custom sizes available.</p> <table border="1"> <tr> <td>11"H x 8"W</td> <td></td> <td>SHD001CLEAR</td> </tr> </table>	11"H x 8"W		SHD001CLEAR			
11"H x 8"W		SHD001CLEAR					
	<p>Slatwall Magazine Pocket</p> <p>Made of clear acrylic.</p> <table border="1"> <tr> <td>11½"H x 9"W</td> <td></td> <td>SHD002CLEAR</td> </tr> </table>	11½"H x 9"W		SHD002CLEAR			
11½"H x 9"W		SHD002CLEAR					
	<p>Slatwall Magazine Holder</p> <p>Made of clear acrylic.</p> <table border="1"> <tr> <td>11½"H x 9"W</td> <td></td> <td>SHD004CLEAR</td> </tr> </table>	11½"H x 9"W		SHD004CLEAR			
11½"H x 9"W		SHD004CLEAR					

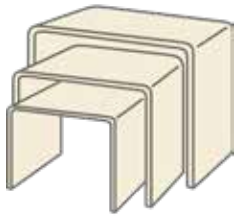

U-Shaped Risers

Made of clear acrylic. Custom sizes available.

3"H x 3"W x 3"D	SHD020CLEAR-3
4"H x 4"W x 4"D	SHD020CLEAR-4
5"H x 5"W x 5"D	SHD020CLEAR-5

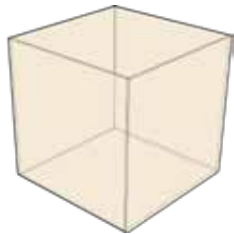

Acrylic Cubes

Made of clear acrylic. Custom sizes available.

6"H x 6"W x 6"D	CUBE666
7"H x 7"W x 7"D	CUBE777
8"H x 8"W x 8"D	CUBE888

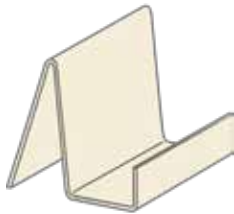

Countertop Book Easel

Made of clear acrylic. Custom sizes available.

SHD003CLEAR

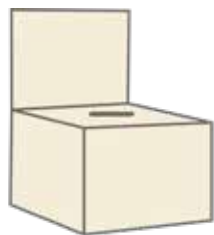

Ballot Box

Made of clear acrylic. Includes a 6½"H x 8"W sign header.

8"H x 8"W x 8"D	SHD005CLEAR
-----------------	-------------

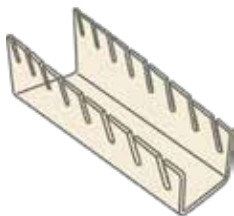

Plate Holder

Made of clear acrylic. Holds up to 8 plates.

SHD015CLEAR

How It Works: Custom Acrylic

Strengthen your brand identity by having your logo engraved on acrylic holders, signs and displays. We can also design and build custom acrylic promotional pieces for your marketing campaigns.





Shelf Ticketing Strips

An amazing array of shelf ticket and inventory management solutions.

Ticketing Display Solutions

Choose from our stock extrusions or let us design the part you need. Custom colours available (minimum order required).

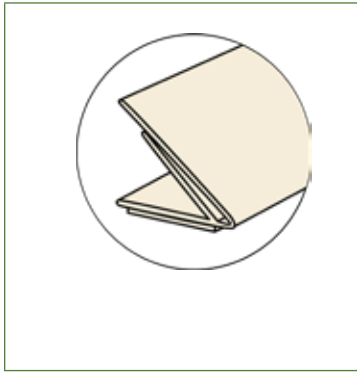

Angled Card Holder with D-Tape

Holds labels on an angle with permanent adhesive tape. Manufactured in PVC. Available in white.

3/4" H x 47 7/8" L

SHE2551

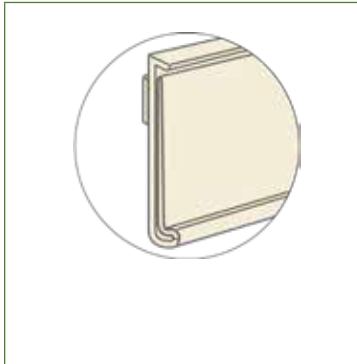

Label Holder with D-Tape

Manufactured in PVC. Available in white, black and clear.

1 1/4" H x 47 7/8" L

SHE0511

1 1/2" H x 47 7/8" L

SHE0619

1 3/4" H x 47 7/8" L

SHE0620

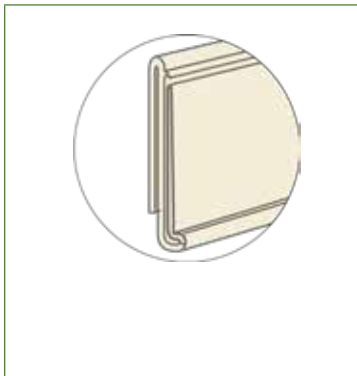

C-Channel Label Holder

Snaps into price channel. Manufactured in PVC. Available in white, black and clear.

1 1/4" H x 47 7/8" L

SHE0711



High Self-Adhesive Data Strip and Label Holder - 2"

Manufactured in PVC. Available in clear.

2" H x 47 7/8" L

SHE2067CLEAR/CLR











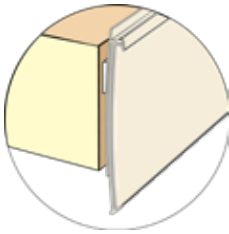

High Self-Adhesive Data Strip and Label Holder - 3"

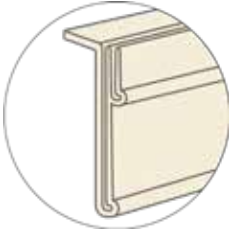
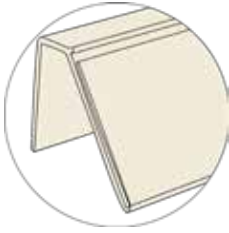
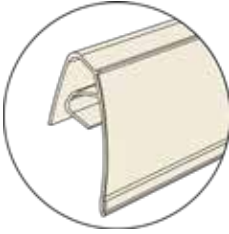

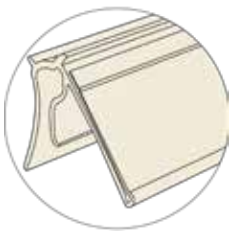

Manufactured in PVC. Available in clear.

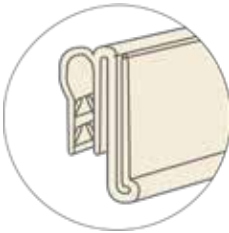
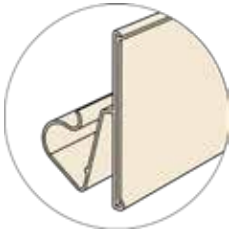

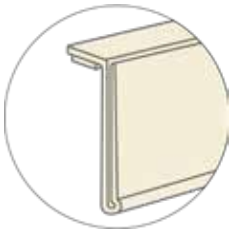

3" H x 47 7/8" L

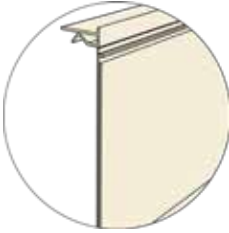
SHE2070 CLR

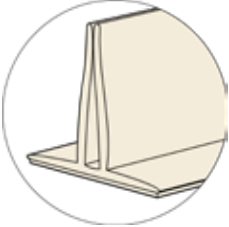

	<p>C-Channel Label Holder with Adhesive</p> <p>Manufactured in PVC. Available in white and clear.</p> <table border="1"> <tr> <td>1¼"H x 47⅞"L</td> <td>SHE3015</td> </tr> </table>	1¼"H x 47⅞"L	SHE3015											
1¼"H x 47⅞"L	SHE3015													
	<p>Flip Label Holder</p> <p>Label holder is slotted with holes for mounting onto standard metal shelves with push pins. Manufactured in clear PVC.</p> <table border="1"> <tr> <td>1¼"H x 47⅞"L</td> <td>SHE0897</td> </tr> <tr> <td>3"H x 47⅞"L</td> <td>SHE2046</td> </tr> </table>	1¼"H x 47⅞"L	SHE0897	3"H x 47⅞"L	SHE2046									
1¼"H x 47⅞"L	SHE0897													
3"H x 47⅞"L	SHE2046													
	<p>Flip Channel - 4"</p> <p>Data Strip mounts to shelf with foam tape or push pins. Available with slot for mounting. Manufactured in clear PVC.</p> <table border="1"> <tr> <td>4" H X 47⅞" L</td> <td>SHE0287CLEAR</td> </tr> </table>	4" H X 47⅞" L	SHE0287CLEAR											
4" H X 47⅞" L	SHE0287CLEAR													
	<p>Sign Holder Extrusion with Data Strip</p> <p>4" high ticket holder with 1¼"H data strip. Manufactured in clear PVC.</p> <table border="1"> <tr> <td>4" H x 47⅞" L</td> <td>SHE2251</td> </tr> </table>	4" H x 47⅞" L	SHE2251											
4" H x 47⅞" L	SHE2251													
	<p>Shelf Label Holder</p> <p>Manufactured in PVC. Available in white and clear.</p> <table border="1"> <tr> <td>1¼"H x 47⅞"L</td> <td>SHE0276</td> </tr> </table>	1¼"H x 47⅞"L	SHE0276											
1¼"H x 47⅞"L	SHE0276													
	<p>Wire Channel Clip</p> <p>Channel clip mounts onto wire. Manufactured in PVC. Available in clear and black.</p> <table border="1"> <tr> <td>1½"H x 23¼"L</td> <td>Clear</td> <td>SHE0191CLEAR/CL23</td> </tr> <tr> <td>1½"H x 23¼"L</td> <td>Black</td> <td>SHE0191BLACK/CL23</td> </tr> <tr> <td>1½"H x 34⅝"L</td> <td>Clear</td> <td>SHE0191CLEAR/CL34</td> </tr> <tr> <td>1½"H x 34⅝"L</td> <td>Black</td> <td>SHE0191BLACK/CL34</td> </tr> </table>	1½"H x 23¼"L	Clear	SHE0191CLEAR/CL23	1½"H x 23¼"L	Black	SHE0191BLACK/CL23	1½"H x 34⅝"L	Clear	SHE0191CLEAR/CL34	1½"H x 34⅝"L	Black	SHE0191BLACK/CL34	
1½"H x 23¼"L	Clear	SHE0191CLEAR/CL23												
1½"H x 23¼"L	Black	SHE0191BLACK/CL23												
1½"H x 34⅝"L	Clear	SHE0191CLEAR/CL34												
1½"H x 34⅝"L	Black	SHE0191BLACK/CL34												

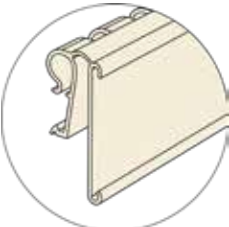

	<h3>Hinged Basket Clip Gripper</h3> <p>Snaps into a C-Channel shelf or clips onto wire or a flat surface. Allows card stock up to 8pt. to hang. Manufactured in PVC. Available in clear.</p> <p>1"H x ¾"W SHC070CLEAR</p>
	<h3>Clear Wire Shelf Ticket Channel</h3> <p>Fits over ¼" wire holder. Manufactured in PVC. Available in clear.</p> <p>1¼"H x 3"L SHE3075CLEAR</p>
	<h3>Clear Dual Extrusion</h3> <p>Clips into C-Channel. Stands alone or clips onto wire. Great for shelf fronts. Manufactured in PVC. Available in clear.</p> <p>2¼"H x 4¼"L SHE2031CLEAR</p>
	<h3>Hinged Extrusion</h3> <p>Mounts to wire or glass up to ⅜" thick. Manufactured in PVC. Available in clear.</p> <p>1¼"H x 47⁄8"L SHE2248CLEAR</p>
	<h3>Wire/Basket Shelf Label Holder</h3> <p>Manufactured in PVC. Available in clear.</p> <p>1"H x 47⁄8"L SHE2136</p>
	<h3>Large Hinged Extrusion</h3> <p>Clips onto wire up to ⅝" thick. Can also be clipped onto glass and into a C-Channel. Manufactured in PVC. Available in clear.</p> <p>3½"H x 6"W SHE2249CLEAR 7"H x 11"W SHE2312CLEAR</p>

	<p>Glass Mount Shelf Label Holder</p> <p>Manufactured in PVC. Available in clear.</p> <p>1"H x 47/8"L SHE2158</p>
	<p>Glass Shelf Extrusion - 90° Angle</p> <p>Attaches to a shelf top with permanent adhesive tape. Manufactured in PVC. Available in clear.</p> <p>1¼"H x 47/8"L SHE1776CLEAR</p>
	<p>Label Holder with D-Tape - 3"</p> <p>Attaches to a flat surface with two pieces of permanent adhesive tape. Manufactured in PVC. Available in white and clear.</p> <p>3"H x 47/8"L SHE2065WHITE</p>
	<p>Flip-Up Label Holder for Shelf Ticket Mouldings - 5"x 3"</p> <p>Clips onto glass or wooden shelf edge. Manufactured in PVC. Available in clear.</p> <p>5"H x 3"L SHE2137</p>
	<p>Straw Clip - 1"</p> <p>Clips onto multiple edges. Available in clear.</p> <p>1"W x 1"H SHE0862CLEAR01</p>
	<p>Bulk Bin Hinge</p> <p>Flexible and durable plastic hinge for bulk-product bins. Grips material up to ¼" thick. Manufactured in PVC. Available in clear.</p> <p>¼"H x 1"L SHE943</p>

	<h3>Gondola Top Card Clip</h3> <p>Holds card stock up to 10 pt. thick. Manufactured in PVC. Available in clear.</p> <p>1"H x 1½"W(Base) x 3"L SHE4485</p>
	<h3>Slatwall Card Holder</h3> <p>Manufactured in PVC. Available in clear.</p> <p>1¼"H x ⅞"W x 2"L SHE0654CLEAR</p>
	<h3>Wire Bin Label Holder</h3> <p>Hooks onto wire and holds labels facing upwards towards the customer for easy reading. Manufactured in PVC. Available in clear.</p> <p>1¼"H x 3"W SHE2006CLEAR</p>
	<h3>Hinged Label Holder</h3> <p>Holder flips up for easy product removal and quick restocking. Manufactured in PVC. Available in clear.</p> <p>1¾"L SHE1058CLEAR-SM 2"L SHE1058CLEAR-LG</p>
	<h3>Warehouse Aisle Invader</h3> <p>Flexible PVC gripper base holds cards vertically to display signage in a flag position. Manufactured in PVC. Available in clear.</p> <p>1⅜"H x 47⅞"L SHE2140</p>
	<h3>Wire Flush Sign Holder with Gripper</h3> <p>Hooks onto wire and holds label on an angle facing upwards for easy reading. Manufactured in PVC. Available in clear.</p> <p>1"H x 1"W SHE0655</p>

	<p>Clear Wire Bin Holder</p> <p>Hooks onto wire and holds label on an angle facing upwards for easy reading. Manufactured in PVC. Available in clear.</p> <p>1"H x 3"W SHE2007</p>
---	--



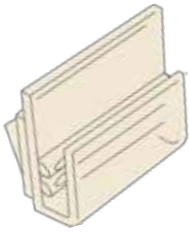

	<p>Hinged Basket Clip</p> <p>Manufactured in clear PVC. Available in custom lengths.</p> <p>3"H x 3½"W SHF0309</p>	
---	--	---

	<p>Basket Clip</p> <p>Manufactured in clear PVC. Available in custom lengths.</p> <p>3"H x 2¾"W SHF0976</p>	
---	---	--

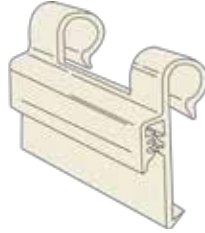
	<p>Sign Holder with Gripper</p> <p>Holds up to 80pt. thick material. Manufactured in clear PVC.</p> <p style="text-align: right;">SHF1802</p>
---	--

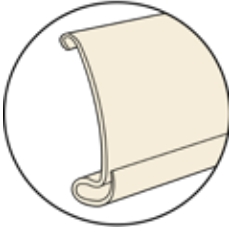
	<p>Flush Sign Holder with Gripper - 1"</p> <p>Holds up to 80pt. thick material. Manufactured in clear PVC.</p> <p style="text-align: right;">SHF4801</p>
---	---

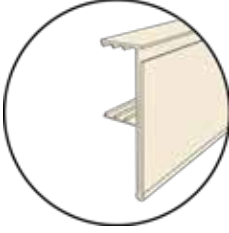
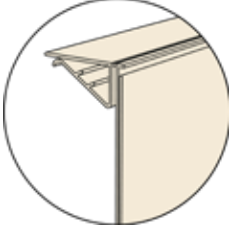
	<p>Wire Sign Holder with Gripper</p> <p>Clips onto wire up to .375" diameter. 1¾" wide holder fits material up to 80pt. thick. Manufactured in clear PVC.</p> <p style="text-align: right;">SHT0619</p>
---	--

	<h3>Clear Peghook Label Holder</h3> <p>Hangs from a peghook. Manufactured in PVC. Available in clear.</p> <p>1¼"H x 47⅞"L SHE2035CLEAR</p>
	<h3>Extrusion Label Holder</h3> <p>Snaps onto a metal C-Channel. Manufactured in PVC. Available in clear.</p> <p>1½"H x 47⅞"L SHE2222</p>
	<h3>Glass / Wood Label Holder - 90°</h3> <p>For ¾" glass shelving. Manufactured in PVC. Available in clear.</p> <p>1¼"H x 47⅞"L SHE2032CLEAR</p>
	<h3>Glass / Wood Label Holder</h3> <p>Manufactured in PVC. For 1½" glass/wood shelving. Available in clear.</p> <p>2"H x 47⅞"L SHE2165CLEAR</p>
	<h3>Glass Shelf Flip-Up Label Holder</h3> <p>Fits on shelf up to ¾" thick. Manufactured in PVC. Available in clear.</p> <p>3"H x 5"L SHE287</p>
	<h3>Glass / Wood Label Holder - 45°</h3> <p>For ½" glass shelving. Manufactured in PVC. Available in white with clear front.</p> <p>1½"H x 47⅞"L SHE1022</p>

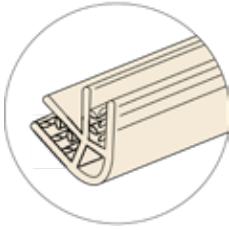

Panel Former with Gripper - 60°

Two-way connector with fixed 60° angle. Conceals unfinished panel edges. 1/8"-1/4" capacity. Available in clear.

48" L

SHF4602

 **How It Works: Double Label Holder**

Various mounting clips makes this label holder versatile. Mounts directly onto a C-Channel or wire bin.

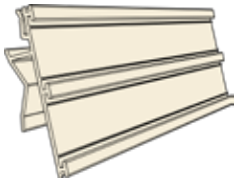

Mounts to C-Channel



Mounts to Wire



Mount to Shovel Base Holder



Mounts to Wire Clip Holder

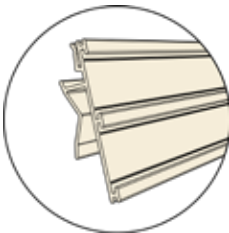

Double Label Holder

Holds two 1 1/8" high labels or one 2 3/8" high label. Manufactured in PVC. Available in white and clear.

2 1/2" H x 8 1/2" L

SHE2380WHITE

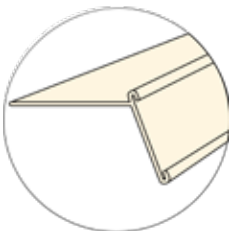

Shovel Base Holder

Attaches to the SHE2380WHITE Double Label Holder, creating a shovel base to display from the edge of a shelf. Available in white.

4" L

SHE2378WHITE04



Wire Clip Holder

Attach the SHE2380WHITE Double Label Holder and display to a flat face. Available in clear.

4" L

SHE2379WHITE04



Universal Label Holder

The Universal Label holder is an innovative shelf ticket holder that gives you six mounting options. It even lets you mount one or two shelf tickets. Available in white and custom colours (minimum order required).

Various Lengths Available

SHE2178

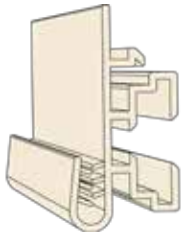

Dual Frame

Dual frame extrusion with gripper that fits 40pt. - 80pt. plastic. Can be hung using standard store hooks or stock stems and accessories. Available in clear, white and black.

Various lengths available 1"- 96"

SHE0817



How It Works: Flag Pole Sign Holder Set

The Flag Pole Sign Holder Set includes:

- SHF0946 Pole Gripper
- SHF0961 Tube Holder

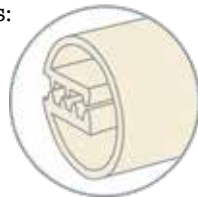

SHF0946
Pole Gripper

+



SHF0961
Tube Holder

=

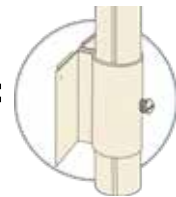

Flag Pole
Sign Holder Set

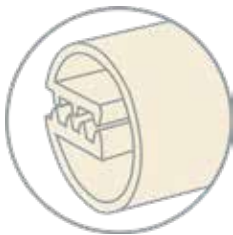

Pole Gripper

Use the Pole Gripper in conjunction with the Tube Holder to display up to 80 pt. signage at various heights and locations. Available in red, blue or custom colours (minimum order required).

SHF0946

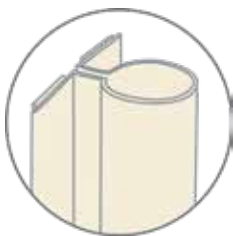

Tube Holder

Complete with double sided tape, the Tube Holder allows the Flag Pole Sign Holder Set to be displayed almost anywhere. Available in red, blue or custom colours (minimum order required).

SHF0961

NEW

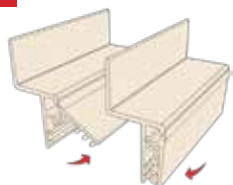

Z-Bar Slatwall Hanging Sign Gripper

Mount signage easily to slatwall. Hanging signage is a snap! Just snap the clear track right onto the edge of your sign. Available in custom lengths.

46"L

SHE0120CLEAR



The Kwickload[®] Pusher System

The Kwickload[®] Pusher System allows for quick and easy product restocking and rotation. A variety of fronts and mounting options makes it ideal for all your merchandising needs.

How It Works: Kwickload® Applications

The Kwickload®* Pusher System is the latest innovative addition to our pusher system family. Its sleek and visually minimal design is ideal for pushing bagged salad, packaged cheese and deli meats.



Kwickload® Display Stand



Kwickload® for Deli



Kwickload® for Produce



Kwickload® for Brick Cheese



Kwickload® for Prepared Foods



Kwickload® for Freezer



Kwickload® for Personal Care Products

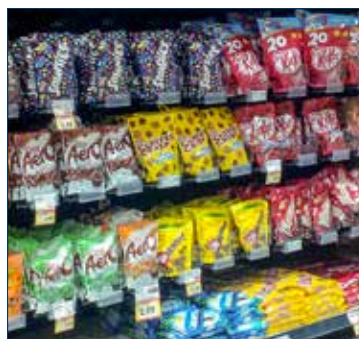

Kwickload® for Confectionary

*US Patent # 9521913



How It Works: Kwickload® Pusher System

- Revolutionary slide out mechanism with locking paddle allows for easy one-handed stock loading and rotation
- Mounting options include standard crossbar and pegboard
- Available in different sizes to accommodate a variety of products
- Durable heavy-duty construction ensures reliability, even in freezers
- Patent pending

1 Choose a Front

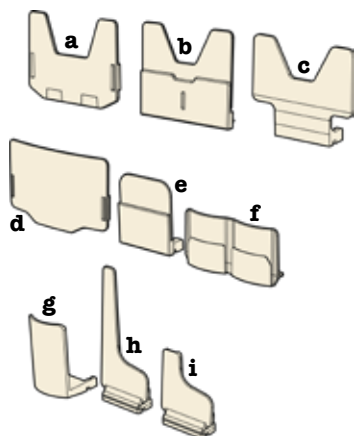

- a** CLRFRNT020 Large Clear Front for Double Track
- b** CLRFRNT002 Clear Front w/ Label Holder
- c** CLRFRNT001 Large Clear Front
- d** CLRFRNT007 Curved Clear Front
- e** CLRFRNT003 Small Clear Front
- f** CLRFRNT015 Double Clear Curved Front
- g** BTLNECKCLEAR Bottle Neck Front
- h** CLRFRNT005 Tall Clear Front
- i** CLRFRNT010 Short Clear Front



2 Select a Mounting System

Kwickload® Pusher Systems can be mounted to most standard store shelves with a Shelf Mount kit. They can also be mounted directly to uprights using a Crossbar Mount kit.

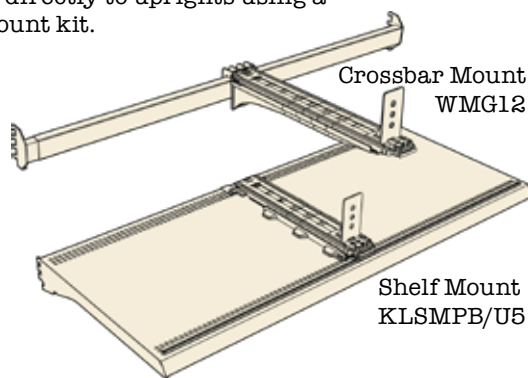

3 Choose the Dividers

Depending on the product being pushed, choose either Moulded Plastic Dividers or Wire ones. Moulded Plastic is designed for boxes items while Wire Dividers work best for bagged items like salad.

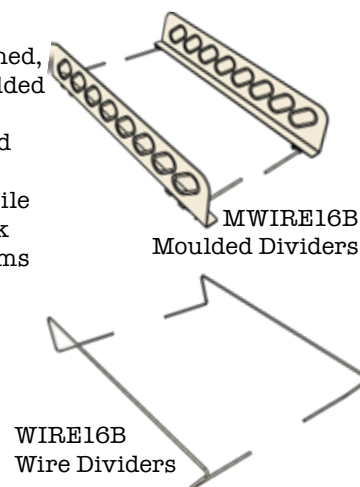

4 Add Optional Components

Customize your Kwickload® setup with add-ons designed for your specific application. The Shelf Cooler Baffle and Support bar helps circulate cold air when pushing products in a freezer.



5 Assemble and Install

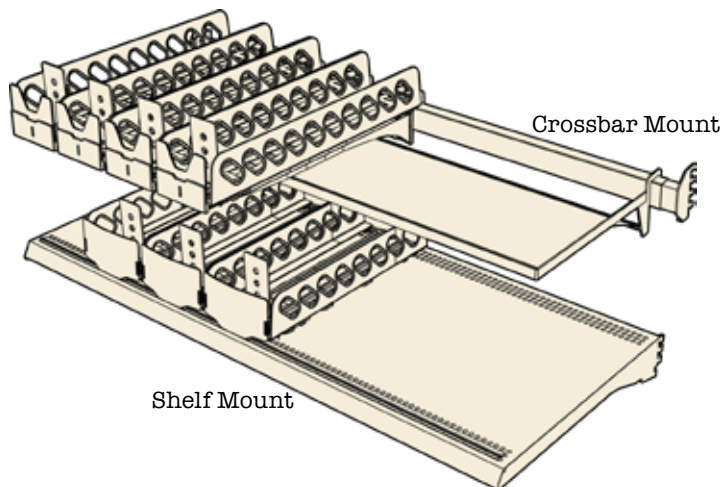

Kwickload® Parts and Accessories

With a variety of components and add-ons, you can tailor your Kwickload® Pusher System to suit your particular needs.

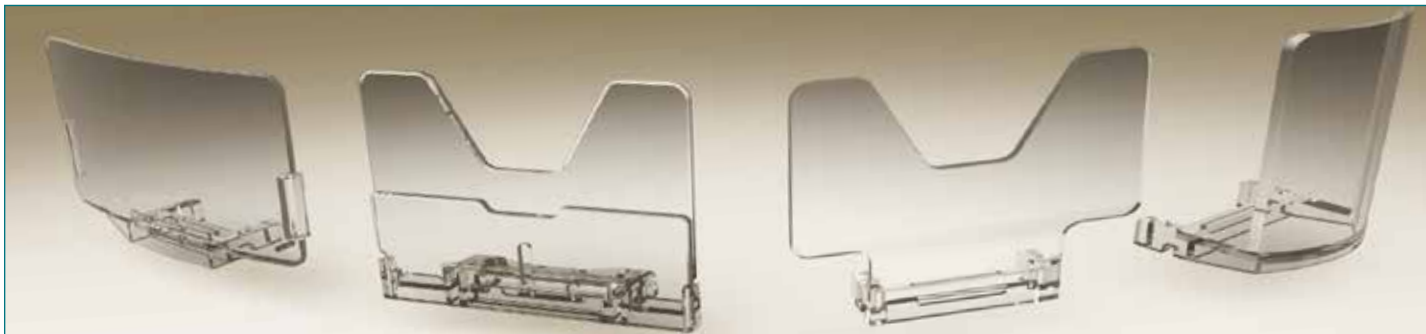

Kwickload® Pusher Fronts



Kwickload® Crossbar Mounting Kits

For 14" tracks	KLMMCM14
For 16" tracks	KLMMCM16
For 18" tracks	KLMMCM18
For 20" tracks	KLMMCM20
For 22" tracks	KLMMCM22

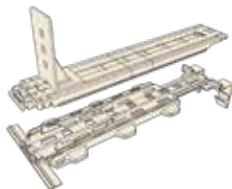

Kwickload® Shelf Mounting Kits

For 14" tracks	KLMSM14
For 16" tracks	KLMSM16
For 18" tracks	KLMSM18
For 20" tracks	KLMSM20
For 22" tracks	KLMSM22

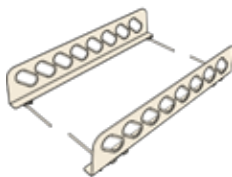

Moulded Dividers

Ideal for merchandising larger items such as bagged salad or pasta. Dividers adjust from 5" to 9" wide. Select the appropriate length to match your Kwickload® track. Injection moulded in high impact styrene. Available in black.

3½"H x 14"L	MWIRE14B
3½"H x 16"L	MWIRE16B
3½"H x 18"L	MWIRE18B
3½"H x 20"L	MWIRE20B
3½"H x 22"L	MWIRE22B





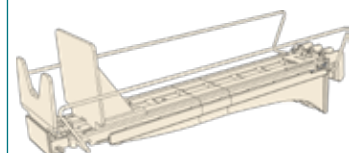

Wire Dividers

Ideal for merchandising smaller items such as candy and deli meats. Dividers are adjustable from 4" to 11" wide. Select the appropriate length to match your Kwickload® track.

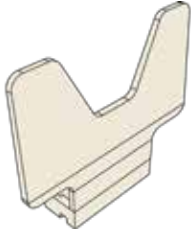
3½"H x 14"L	WIRE14B
3½"H x 16"L	WIRE16B
3½"H x 18"L	WIRE18B
3½"H x 20"L	WIRE20B
3½"H x 22"L	WIRE22B

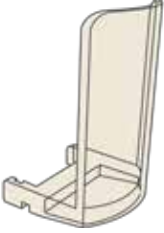
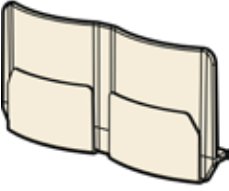

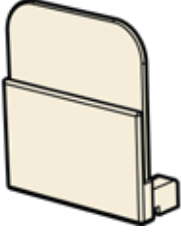
	<p>Pusher Front - Clear</p> <p>The Clear Front Plate can be attached to our Multi-Use Heavy and Medium Duty Pusher Systems. Manufactured in clear polycarbonate.</p> <p>4½”H x 3¾”W CLRFRNT001</p>
	<p>Pusher Front - Curved</p> <p>The Curved Pusher Front can be attached to our Multi-Use Heavy Duty, Multi-Use Medium Duty, and Kwickload® Pusher Systems. Ideal for bagged products. Manufactured in clear polycarbonate.</p> <p>4”H x 6½”W CLRFRNT007</p>
	<p>Pusher Front - Bottle</p> <p>The Bottle Pusher Front can be attached to our Multi-Use Heavy Duty, Multi-Use Medium Duty and Kwickload® Pusher Systems. Manufactured in clear polycarbonate.</p> <p>3⅞”H x 2⅜”W BTNFRONT</p>
<p>NEW</p> 	<p>Double Curved Pusher Front - Clear</p> <p>The Double Curved Pusher Front works with our double track Kwickload®. The curved fronts are designed to support beverage bottles and cans like flavour drops or energy drinks. Manufactured in clear polycarbonate.</p> <p>2½”H x 4⅞”W CLRFRNT015</p>
<p>NEW</p> 	<p>Pusher Front with Label Holder - Clear</p> <p>The Clear Pusher Front with Label Holder works with our Kwickload® pusher system and features an integrated track to labels and product information. Manufactured in clear polycarbonate.</p> <p>4”H x 4¾”W CLRFRNT002</p>
<p>NEW</p> 	<p>Small Pusher Front - Clear</p> <p>The Small Clear Pusher Front works with our Kwickload® pusher system. Manufactured in clear polycarbonate.</p> <p>3¼”H x 3”W CLRFRNT003</p>

NEW

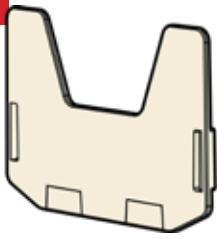

Large Wide Pusher Front - Clear

The Large Wide Clear Pusher works with our Kwickload® pusher system. Manufactured in clear polycarbonate.

3 7/8" H x 5 1/2" W

CLRFRNT020

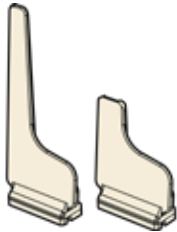

Pusher Front - Finger

The Finger Pusher Fronts can be attached to our multi-use heavy and medium duty pusher systems and Kwickload® Pusher Systems. Manufactured in clear polycarbonate.

6 3/4" H x 3" W

Tall

CLRFRNT005

3 1/2" H x 3" W

Short

CLRFRNT010

Kwickload® Cooler Accessories



Hook Bar C-Clamp with Label Plate

Made with 1/4" steel wire and designed for heavier products, such as deli meats. Mounts onto our Adjustable Crossbar. Available in black. Custom sizes available (minimum order required).

18" L

HKBARC001



Metal Shelf

Heavy duty construction, designed to mount onto our Adjustable Crossbar. Available in black. Custom sizes available (minimum order required).

SHLFMET001



How It Works: Shelf Cooler Baffle and Support Bar

1 Attach Adjustable Crossbar to shelf uprights

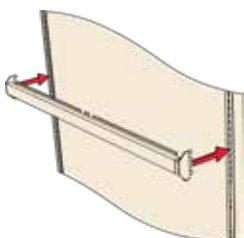

2 Attach Kwickload® Cooler Baffle Frame to Adjustable Crossbar

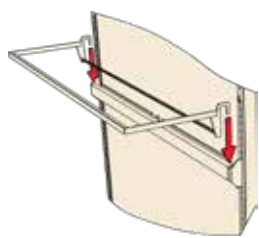

3 Add Kwickload® Cooler Baffle to Adjustable Crossbar

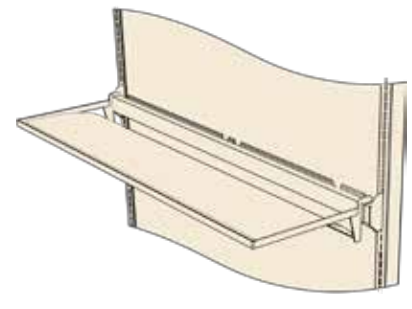
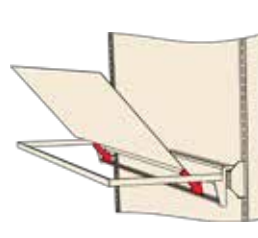

	Adjustable Crossbar	
	Designed to mount directly to gondola uprights. Easy to install, this Crossbar will adjust to fit 46½" to 48" centers and is a required component for the Kwickload® Crossbar Mount, Support Bar, Shelf Freezer Baffle, Hook Bar C-Clamp, and Deli Shelf. Made of steel. Available in black.	
	24"L	CROBAR003
	30"L	CROBAR007
	36"L	CROBAR008
48"L	CROBAR001R	

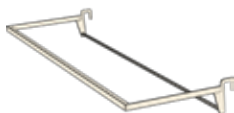
	Support Bar	
	Recommended for use with 20" and 22" Crossbars. Also works with the Adjustable Crossbar.	
		BAFSUPBAR

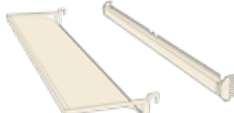
	Shelf Cooler Baffle and Support Bar	
	The Shelf Cooler Baffle redirects cool air forward to provide even cooling to the front-most products. and mounts to the Adjustable Crossbar. Steel frame with a high-density polyethylene insert.	
	Kit Includes: 1 - Baffle Support Bar 1 - Baffle 1 - Adjustable Crossbar	
		BAFSUPSET

Popular Kwickload® Kits





Kwickload® for Bagged Candy





Kwickload® for Deli



Kwickload® for Freezer Goods

	Kwickload® Bagged Cheese Kit - Crossbar Mount		
	Designed and optimized for bagged shredded cheese.		
	with Support Bar	CMK018C-SB	
without Support Bar	CMK018C		

	Kwickload® Brick Cheese Kit - Crossbar Mount		
	Designed and optimized for brick cheese.		
	with Support Bar	CMK018BC-SB	
without Support Bar	CMK018BC		



Modular Merchandising Systems

Total shelf merchandising flexibility with versatile pushers, dividers and category management accessories.

Spring Loaded Pushers

Give your sales a push! Our pushers keep your products up front where customers can see and buy them! Made from practically unbreakable high-impact styrene, our pushers fit any shelving system and are maintenance free! Available in white, black and custom colours (minimum order required).



Gen 2 Light Duty Pusher System with 2" Adjustable Dividers



How It Works: Gen2 Light Duty Pusher System with Individual Fronts

Our new low profile Light Duty Pusher System* incorporates our slide and lock mechanism for unlimited layout adjustability that adapts to your product needs. This light duty pusher system is the perfect companion for our shelf dividers.

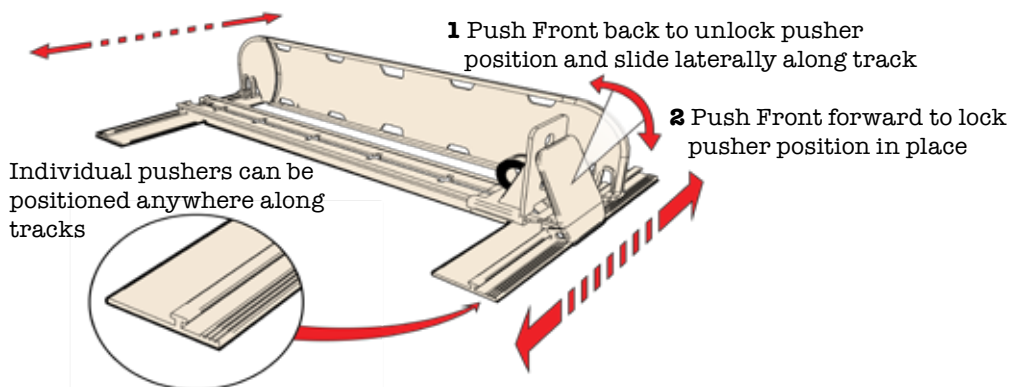

*Patent Pending

NEW



Gen2 Light Duty Pusher with Individual Fronts - 7/8" Wide

Available in black and white. Custom colours also available (minimum order required).

12"L	LP12G2 BLACK / WHITE -I
14"L	LP14G2 BLACK / WHITE -I
16"L	LP16G2 BLACK / WHITE -I
18"L	LP18G2 BLACK / WHITE -I

NEW



Gen2 Light Duty Pusher for Front Fence - 7/8" Wide

Available in black and white. Custom colours also available (minimum order required).

12"L	LP12G2 BLACK / WHITE -F
14"L	LP14G2 BLACK / WHITE -F
16"L	LP16G2 BLACK / WHITE -F
18"L	LP18G2 BLACK / WHITE -F



How It Works: Pushers and Dividers

Equipping your shelves with Pushers and Dividers is quick and easy. First attach the snap bars to your shelves. Then snap the spring loaded pushers and dividers into place and adjust their position by easily sliding them left or right. We carry Pushers and Dividers for almost any shelving system.

Visit our website, displaypeople.com, to learn more.

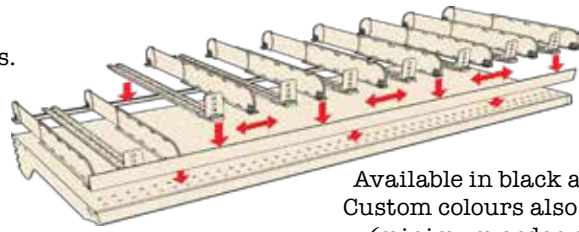

Available in black and white.
Custom colours also available
(minimum order required).

	Light Duty Pusher - 7/8" Wide	
	6"L	LP06
	8"L	LP08
	10"L	LP10

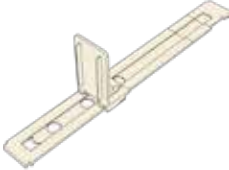
	Medium Duty Pusher - 2" Wide	
	12"L	MP12
	14"L	MP14
	16"L	MP16
	18"L	MP18

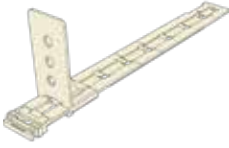

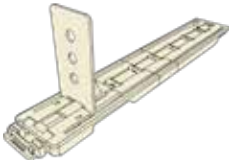

	Multi-Use Medium Duty Pusher	
	14"L	MCMP14
	16"L	MCMP16
	18"L	MCMP18
	20"L	MCMP20
	22"L	MCMP22

	Heavy Duty Pusher - 3" Wide	
	12"L	HP12
	14"L	HP14
	16"L	HP16
	18"L	HP18

	Multi-Use Heavy Duty Pusher	
	14"L	CMP14
	16"L	CMP16
	18"L	CMP18
	20"L	CMP20
	22"L	CMP22

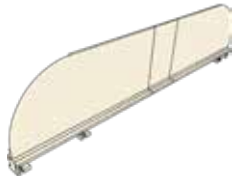
Snap In Shelf Dividers

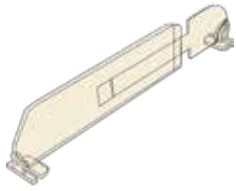
Our patented Shelf Divider adjusts to fit most shelf depths and attaches quickly with our T-snap tracks. They can be used alone or with our Spring-Loaded pushers to keep merchandise organized and to reduce theft from 'shelf sweeping'.

<p>NEW</p> 	<p>Gen2 Snap-In Adjustable Divider - 2" and 4"</p> <p>Available in black and white. Custom colours also available (minimum order required). US Patent #5625969</p> <table border="1"> <tr> <td>2"H x 12" - 16"L</td> <td>DIVG2T210</td> </tr> <tr> <td>2"H x 16" - 20"L</td> <td>DIVG2T216</td> </tr> <tr> <td>4"H x 12" - 16"L</td> <td>DIVG2T410</td> </tr> <tr> <td>4"H x 16" - 20"L</td> <td>DIVG2T416</td> </tr> </table>	2"H x 12" - 16"L	DIVG2T210	2"H x 16" - 20"L	DIVG2T216	4"H x 12" - 16"L	DIVG2T410	4"H x 16" - 20"L	DIVG2T416	
2"H x 12" - 16"L	DIVG2T210									
2"H x 16" - 20"L	DIVG2T216									
4"H x 12" - 16"L	DIVG2T410									
4"H x 16" - 20"L	DIVG2T416									
	<p>Heavy Duty Divider</p> <p>Available in black and white high impact styrene. Custom colours also available (minimum order required).</p> <table border="1"> <tr> <td>4"H x 16"L</td> <td>DIV16</td> </tr> <tr> <td>4"H x 18"L</td> <td>DIV18</td> </tr> <tr> <td>4"H x 20"L</td> <td>DIV20</td> </tr> <tr> <td>4"H x 22"L</td> <td>DIV22</td> </tr> </table>	4"H x 16"L	DIV16	4"H x 18"L	DIV18	4"H x 20"L	DIV20	4"H x 22"L	DIV22	
4"H x 16"L	DIV16									
4"H x 18"L	DIV18									
4"H x 20"L	DIV20									
4"H x 22"L	DIV22									
	<p>Snap-In Divider - 2"</p> <p>Moulded in clear polycarbonate. Available in black and white high impact styrene as well as custom colours (minimum order required).</p> <table border="1"> <tr> <td>2"H x 7"L</td> <td>DIVT207WHITE</td> </tr> </table>	2"H x 7"L	DIVT207WHITE							
2"H x 7"L	DIVT207WHITE									
	<p>Snap-In Adjustable Divider - 2"</p> <p>Moulded in clear polycarbonate. Available in black and white high impact styrene as well as custom colours (minimum order required). US Patent #5625969</p> <table border="1"> <tr> <td>2"H x 10"-16"L</td> <td>DIVT210</td> </tr> </table>	2"H x 10"-16"L	DIVT210							
2"H x 10"-16"L	DIVT210									
	<p>Snap-In Divider with Front Stops - 2"</p> <p>Moulded in clear polycarbonate. Custom colours available in high-impact styrene (minimum order required).</p> <table border="1"> <tr> <td>2"H x 7"L</td> <td>Left Divider</td> <td>DIVL207CLRFRTHS</td> </tr> <tr> <td>2"H x 7"L</td> <td>Right Divider</td> <td>DIVR207CLRFRTHS</td> </tr> <tr> <td>2"H x 7"L</td> <td>Centre Divider</td> <td>DIVT207CLRFRT</td> </tr> </table>	2"H x 7"L	Left Divider	DIVL207CLRFRTHS	2"H x 7"L	Right Divider	DIVR207CLRFRTHS	2"H x 7"L	Centre Divider	DIVT207CLRFRT
2"H x 7"L	Left Divider	DIVL207CLRFRTHS								
2"H x 7"L	Right Divider	DIVR207CLRFRTHS								
2"H x 7"L	Centre Divider	DIVT207CLRFRT								

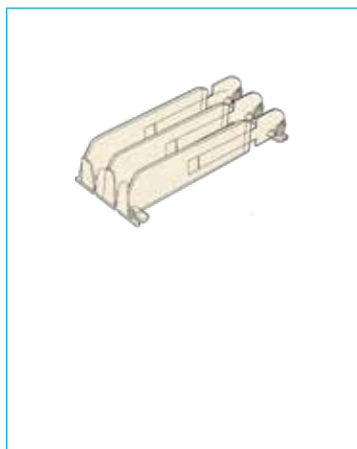

Snap-In Adjustable Divider with Front Stops - 2"		
Moulded in clear polycarbonate. Custom colours available in high-impact styrene (minimum order required).		
US Patent #5625969		
2"H x 10"-16"L	Left Divider	DIVL210CLRFRTHS
2"H x 10"-16"L	Right Divider	DIVR210CLRFRTHS
2"H x 10"-16"L	Centre Divider	DIVT210CLRFRTHS
2"H x 16"-22"L	Left Divider	DIVL216CLRFRTHS
2"H x 16"-22"L	Right Divider	DIVR216CLRFRTHS
2"H x 16"-22"L	Centre Divider	DIVT216CLRFRTHS

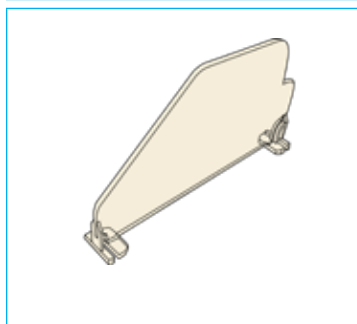

Snap-In Divider - 4"		
Moulded in clear polycarbonate. Available in black and white high impact styrene as well as custom colours (minimum order required).		
4"H x 7"L		DIV407CLEAR

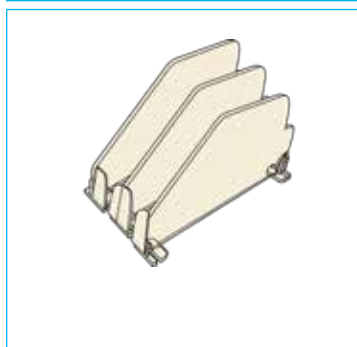

Snap-In Divider with Front Stops - 4"		
Moulded in clear polycarbonate.		
4"H x 7"L	Left Divider	DIVL407CLRFRTHS
4"H x 7"L	Right Divider	DIVR407CLRFRTHS
4"H x 7"L	Centre Divider	DIVT407CLRFRTHS

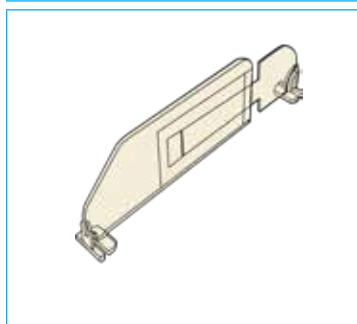



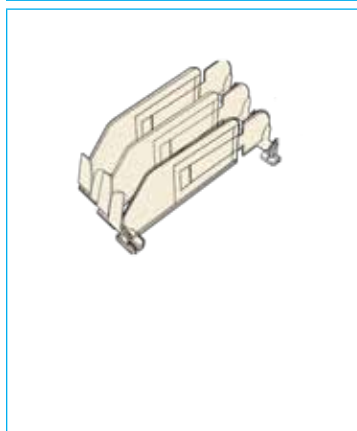

Snap-In Adjustable Divider - 4"		
Moulded in clear polycarbonate. Available in black and white high impact styrene as well as custom colours (minimum order required).		
US Patent #5625969		
4"H x 10"-16"L		DIVT410
4"H x 16"-22"L		DIVT416

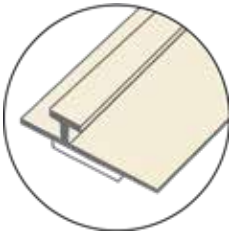

Snap-In Adjustable Divider with Front Stops - 4"		
Moulded in clear polycarbonate.		
US Patent #5803276.		
4"H x 10"-16"L	Left Divider	DIVL410CLRFRTHS
4"H x 10"-16"L	Right Divider	DIVR410CLRFRTHS
4"H x 10"-16"L	Centre Divider	DIVT410CLRFRTHS
4"H x 16"-22"L	Left Divider	DIVL416CLRFRTHS
4"H x 16"-22"L	Right Divider	DIVR416CLRFRTHS
4"H x 16"-22"L	Centre Divider	DIVT416CLRFRTHS

Snap Bars

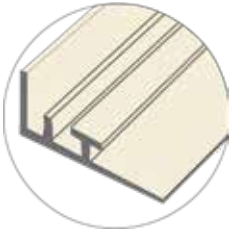
Snap Bars are used to attach spring-loaded pushers and adjustable dividers to shelves. Apply with double-sided tape, magnetic tape, push pins or screws (specify preferred method when ordering). Moulded in durable clear PVC. Custom lengths available.

	<p>Rear T-Snap - Punched</p> <p>Affix to the front or rear of a shelf to support Pushers and Dividers.</p> <table border="1"> <tr> <td>$\frac{1}{4}$"H x $47\frac{7}{8}$"L x $1\frac{1}{8}$"D</td> <td>With holes</td> <td>SA127</td> </tr> </table>	$\frac{1}{4}$ "H x $47\frac{7}{8}$ "L x $1\frac{1}{8}$ "D	With holes	SA127									
$\frac{1}{4}$ "H x $47\frac{7}{8}$ "L x $1\frac{1}{8}$ "D	With holes	SA127											
	<p>Rear T-Snap - With Tape</p> <p>Affix to the front or rear of a shelf to support Pushers and Dividers.</p> <table border="1"> <tr> <td>$\frac{1}{4}$"H x $47\frac{7}{8}$"L x $1\frac{1}{8}$"D</td> <td>With tape</td> <td>SA127DTAPE</td> </tr> </table>	$\frac{1}{4}$ "H x $47\frac{7}{8}$ "L x $1\frac{1}{8}$ "D	With tape	SA127DTAPE									
$\frac{1}{4}$ "H x $47\frac{7}{8}$ "L x $1\frac{1}{8}$ "D	With tape	SA127DTAPE											
	<p>Label Holder Snap Bar</p> <p>Holds labels on the front of shelves and provides support for our pushers and dividers</p> <table border="1"> <tr> <td>2"H x 48"W x $1\frac{1}{2}$"D</td> <td></td> <td>SA222</td> </tr> <tr> <td>$1\frac{1}{4}$"H x 48"W x $1\frac{1}{2}$"D</td> <td></td> <td>SA125</td> </tr> </table>	2"H x 48"W x $1\frac{1}{2}$ "D		SA222	$1\frac{1}{4}$ "H x 48"W x $1\frac{1}{2}$ "D		SA125						
2"H x 48"W x $1\frac{1}{2}$ "D		SA222											
$1\frac{1}{4}$ "H x 48"W x $1\frac{1}{2}$ "D		SA125											
	<p>Snap Bar and Label Holder</p> <p>Supports Adjustable Dividers, Adjustable T-Dividers and all Pushers.</p> <table border="1"> <tr> <td>$48\frac{7}{8}$"L</td> <td>With holes</td> <td>SHE2177CLEAR</td> </tr> <tr> <td>$48\frac{7}{8}$"L</td> <td>With D-tape</td> <td>SHE2177CLEARDTAPE</td> </tr> </table>	$48\frac{7}{8}$ "L	With holes	SHE2177CLEAR	$48\frac{7}{8}$ "L	With D-tape	SHE2177CLEARDTAPE						
$48\frac{7}{8}$ "L	With holes	SHE2177CLEAR											
$48\frac{7}{8}$ "L	With D-tape	SHE2177CLEARDTAPE											
	<p>Front Fence - Clear</p> <p>Affix to the front of a shelf. Can be used with our Pushers and Dividers.</p> <table border="1"> <tr> <td>$1\frac{1}{2}$"H x $47\frac{7}{8}$"W</td> <td>With holes</td> <td>CLEARFENCE1548</td> </tr> <tr> <td>$1\frac{7}{8}$"H x $47\frac{7}{8}$"W</td> <td></td> <td>CLEARFENCE11316</td> </tr> <tr> <td>$2\frac{1}{4}$"H x $47\frac{7}{8}$"W</td> <td></td> <td>CLEARFENCE225R</td> </tr> <tr> <td>3"H x $47\frac{7}{8}$"W</td> <td></td> <td>CLEARFENCE348</td> </tr> </table>	$1\frac{1}{2}$ "H x $47\frac{7}{8}$ "W	With holes	CLEARFENCE1548	$1\frac{7}{8}$ "H x $47\frac{7}{8}$ "W		CLEARFENCE11316	$2\frac{1}{4}$ "H x $47\frac{7}{8}$ "W		CLEARFENCE225R	3"H x $47\frac{7}{8}$ "W		CLEARFENCE348
$1\frac{1}{2}$ "H x $47\frac{7}{8}$ "W	With holes	CLEARFENCE1548											
$1\frac{7}{8}$ "H x $47\frac{7}{8}$ "W		CLEARFENCE11316											
$2\frac{1}{4}$ "H x $47\frac{7}{8}$ "W		CLEARFENCE225R											
3"H x $47\frac{7}{8}$ "W		CLEARFENCE348											

Popular Shelf Pusher Kits

Our pusher kits are a simple and effective solution for shelf merchandising. Made from high-impact styrene, our pusher kits fit any shelving system and are maintenance free. Just install and add your product! Custom kit depths and widths can be created to fit all your shelving needs.



Universal 2" Light Duty Pusher Kit

NEW



Universal 2" Light Duty Pusher Kit

Can be used for a variety of products ranging from small to large sizes. Custom prepacked systems are available upon request. Metal shelf not included.

Kit Includes:
 18 - Pushers
 19 - Dividers
 2" Snap-In Adjustable Dividers
 1- ½" Clear Fence
 1 - Back Rail

2¼"H x 48"W x 12"-16"D

DIVG2TKIT216F-B/W

NEW



Slide and Lock Light Duty Pusher Kit

Can be used for a variety of small to medium size products. Custom prepacked systems are available upon request. Metal shelf not included.

Kit Includes:
 18 - 16" Deep Pushers with Springs
 19 - 2" Snap-In Adjustable Dividers
 18- Individual fronts
 2 - Snap Rails

2¼"H x 48"W x 12-16"D

DIVG2TKIT216I-B/W



Slide and Lock Light Duty Pusher Kit



Medium Duty Pusher System with 2" Adjustable Snap-In Dividers and Front Fence

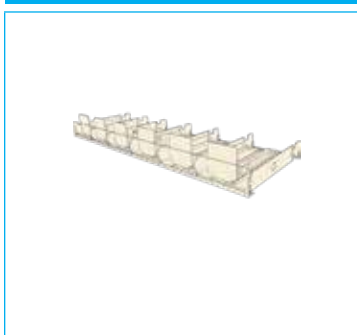

Deli / Cheese Pusher Kit - 14" Deep

- Kit Includes:
- 6 - Pushers with Extra Large Paddles
 - 7 - Dividers
 - 1 - 3" Clear Front Fence
 - 1 - Basic Rail

Deli Pusher Kit	DELIPUSHSYS46P14
Cheese Pusher Kit	SHELFSYS303B22

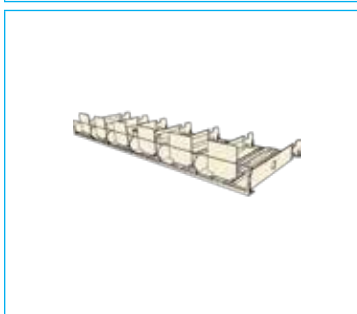

Produce Pusher Kit - 16" Deep

- Kit Includes:
- 6 - Pushers with Extra Large Paddles
 - 7 - Dividers
 - 1 - 3" Clear Front Fence
 - 1 - Basic Rail

Produce Pusher Kit	PUSHSYS417P1
--------------------	--------------



Shelf Mounted Bottle Pusher Kit - 16" Deep

- 500ml and 1L Bottle Kit Includes:
- 14 - Pushers with Bottle Fronts
 - 15 - Dividers
 - 2 - Basic Rails

500ml/1L Pusher Kit	SHELFBOT406
---------------------	-------------

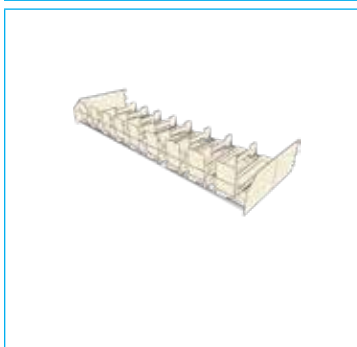

DVD/Video Game Pusher Kit

Kit fits 48" wide and 16" deep shelves.
Mounts directly to store uprights.

- Kit Includes:
- 8 - Heavy Duty Pushers
 - 7 - 4" high Dividers
 - 1 - Metal Hanging Shelf
 - 1 - Basic Snap Rail

DVD/Video Game Pusher Kit	SHELFDVD408W16
---------------------------	----------------



	<p>Freezer Pusher Kit - 22" Deep</p> <p>Kit fits 22" deep shelves. Kit Includes: 4 - Heavy Duty Pushers 5 - Dividers 1 - 3" Front Fence (32"L) 1 - Basic Snap Rail</p> <p>Freezer Pusher Kit FREEZERPUSH404W22</p>	
	<p>Paper Plate Pusher Kit</p> <p>Kit fits 22" deep shelves. Kit Includes: 8 - Heavy Duty Pusher 9 - Dividers 1 - 3" Front Fence (48"L) 1 - Basic Snap Rail</p> <p>Paper Plate Pusher Kit PLATEPUSH408W22</p>	
	<p>Chocolate Bar Pusher Kit</p> <p>Hangs on Upright. Kit Includes: 1- Metal Hanging Shelf 13 - Multi-Use Heavy Duty Pushers with Clear Gum Fronts 12 - Dividers (DIV20) 2 - T-Snap rails 1 - Label Holder with D-Tape</p> <p>Chocolate Bar Pusher Kit BARPUSH420M4HK</p>	
	<p>Gum Pusher Kit</p> <p>Kit Includes: 11 - Heavy Duty Pusher 10 - Dividers 1 - 3" Front Fence (48"L) 2 - Metal Side Gables 1 - Basic Snap Rail</p> <p>48"W x 20"D SHELFGUM42B08</p>	
<p>NEW</p> 	<p>Adjustable Tray Style Pusher Kit</p> <p>Fits most products from 4"- 8" wide. Dividers are connected to the pusher plate and adjust left and right for wider packs. Kit fits 48"W x 16"D shelves. Kit Includes: 1" - 3" Front Fence 8 - Pushers Trays complete with Dividers 1 - Basic T-Snap rail</p> <p>Adjustable Tray Style Pusher Kit TRAYSHFB1608</p>	

Hanging/Shelf Mounted Pusher System



Adjustable Hanging Pusher System

How It Works: Hanging/Shelf Mounted Pusher System

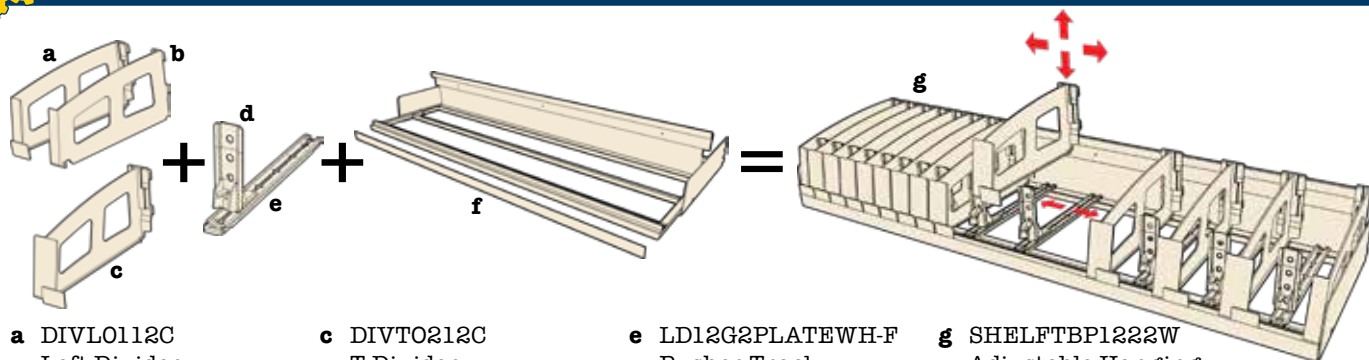

- a** DIVL0112C
Left Divider
- b** DIVR0112C
Right Divider

- c** DIVT0212C
T-Divider
- d** TLDPADDLEANG
Tall Light Duty Paddle

- e** LD12G2PLATEWH-F
Pusher Track
- f** PULCROBARG2
Pullout Shelf

- g** SHELFTBP1222W
Adjustable Hanging
Pusher System

US Patent # 9642475 B2

NEW



Adjustable Hanging Pusher System

With Patented pull-out crossbar.

US Patent #9642475 B2

28⁷/₈"L

SHELFTBP1222W

NEW

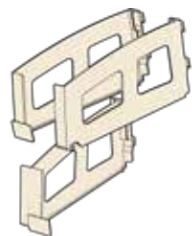

Dividers for Hanging Pusher System

Left Divider	DIVG2L0112C
Right Divider	DIVG2R0112C
T Divider	DIVG2T0112C

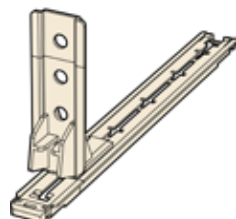

Pusher Track for Hanging Pusher System

LD12G2PLATEWH-F



Adjustable Hanging Pusher System



Adjustable Hanging Pusher System

NEW

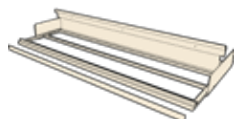

Pullout Shelf

Gondola mounted pullout shelf with locking mechanism. Makes loading and restocking your product quick and easy.

US Patent #9642475 B2

PULCROBARG2

Shelf Mounting Dividers

How It Works: Sliding Pin Divider

The sliding pin mechanism minimizes gaps between products and dividers, allowing you to maximize the number of products on a shelf.

Its one-piece construction allows for simple installation and maintenance and the dual-fastening system (front pin and back track) securely attaches it to the shelf.

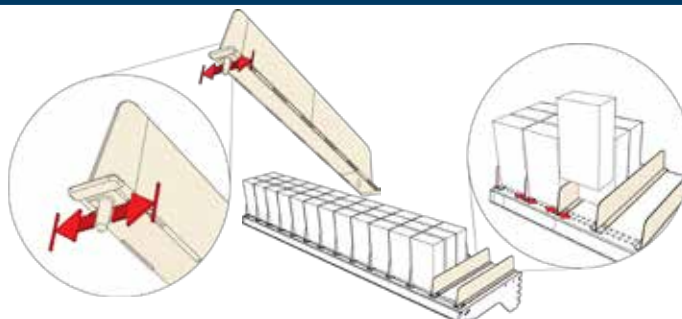

NEW

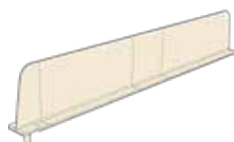

Sliding Pin Divider

Moulded in clear polycarbonate.

US Patent #5803276

2" H x 12" L

DIVT212CLEARMP

2" H x 14" L

DIVT214CLEARMP

2" H x 16" L

DIVT216CLEARMP

2" H x 18" L

DIVT218CLEARMP



Sliding Pin Dividers

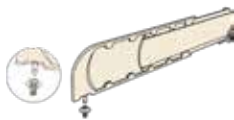

Thin Adjustable Clip-In Divider

Moulded in clear polycarbonate. Available in black and white high impact styrene. Custom colours available (minimum order required).

US Patent #5803276.

2"H x 10"-16"L	DIVP001
----------------	---------

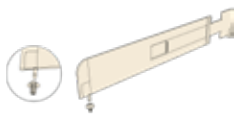

Adjustable Clip-In Divider

Moulded in clear polycarbonate. Available in black and white high impact styrene.

US Patent #5625969

2"H x 16"-22"L	DIVP216
----------------	---------



Snap-In Adjustable T-Divider

Adjusts from 12"-16". Fastens onto front and Rear Snap Bars for easy shelf attachment. Moulded in high-impact crystal styrene. Hardware sold separately.

US Patent #5625969

5"H x 4"W x 16"D	Left End	DIVL512
5"H x 2"W x 16"D	Right End	DIVR512
5"H x 2"W x 16"D	Centre T	DIVT512



Small Divider



Attaches to holes in metal shelves. Moulded in clear crystal styrene.

3"H x 1½"W x 3"D	Left Divider	DIVL73
3"H x 1½"W x 3"D	Right Divider	DIVR73
3"H x 3"W x 3"D	Centre Divider	DIVT73

 **How It Works: Sliding T Divider**

Our new sliding T Divider* features a sliding pin mechanism that securely locks the divider to the shelf and gives you the ability to shift individual dividers left and right. This lets you minimize gaps between products and increase the number of facings per shelf. Sliding T dividers keep your products organized and maximize your shelf space potential.

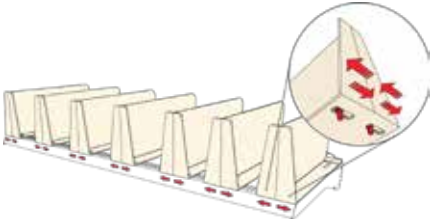
*Patent Pending

Large Divider

Attaches to holes in metal shelves. Moulded in clear crystal styrene.

7"H x 2"W x 16"D	Left Divider	DIVL167
7"H x 2"W x 16"D	Right Divider	DIVR167
7"H x 4"W x 16"D	Centre Divider	DIVT167



Large Clear Divider with T-Shaped Base

Extruded in clear PVC with radius corners. Custom lengths available (minimum order required).

3½"H x 9¾"L

SHF0485CLEAR

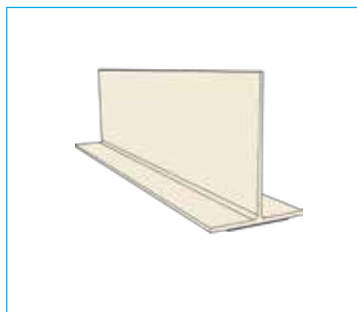

Small Clear Divider with T-Shaped Base

Clear PVC with clear Tesa Tape. Custom lengths available (minimum order required).

1"H x 10¼"L

SHE2502



Greeting Card Divider

The Greeting Card Divider system reinforces existing card fixtures and keeps your product organized. Adjustable height from 4" to 6". The integrated folding sign holder allows for double-sided graphics. Fits most wire and flat fences. Made of Polyethylene. Custom colours available (minimum order required).

4"- 6"H

CARDDIV104

Shelf Management Mats & Trays

Make the most efficient use of your shelf space and keep products organized with our Shelf Management Mats and Trays. Perfect for cosmetics and other small items, Mats and Trays can be linked together to span the length of any shelf. Insert optional pushers and special dividers for a complete merchandising system.



Seven Track Pusher Nail Tray



Cosmetic Tray with Dividers

NEW

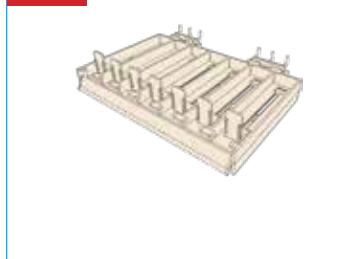

Seven Track Pusher Nail Tray

Clear tray with flip-front label holder. Made of crystal styrene.

2¼" H x 12" W x 8" D

COSMTRAY-03CLR

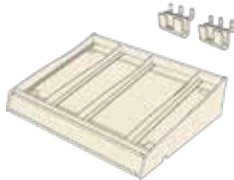

Cosmetics Tray

Clear tray with flip-front label holder. Rests on a counter or hooks onto a wall. Locks together on sides. Moulded in crystal styrene. Includes two clear Pegboard/Slatwall U-hooks.

11 $\frac{7}{8}$ "W x 8"D	Clear	COSMTRAY-01
11 $\frac{7}{8}$ "W x 8"D	Black	COSMTRAY-02BK



Cosmetic Tray Divider

Dividers for use with our Cosmetics trays, that slide left and right to adjust to your product's width. Moulded in clear styrene.

1 $\frac{7}{8}$ "H x 8"D	Clear	COSMDIV208
1 $\frac{7}{8}$ "H x 8"D	Black	COSMDIV208BK



Shelf Management Mat

Individual sections connect along the side to extend the width of any shelf. Each section is 11 $\frac{1}{2}$ " wide.

10" Deep	SHETRA-10CL
12" Deep	SHETRA-12CL
14" Deep	SHETRA-14CL



Shelf Management Mat Dividers

Dividers are 2" high. Available in 3 lengths.

2"H x 10"L	SHEDIV2-10CL
2"H x 12"L	SHEDIV2-12CL
2"H x 14"L	SHEDIV2-14CL



Light Duty Pusher - $\frac{7}{8}$ " Wide

To be used with our Cosmetics Tray and Shelf Management Mat.

8" Long Pusher	LP08
----------------	------

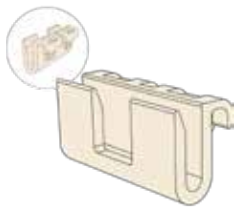

Wire / Flat Fence U-Hook - Clear

Used to hang items from a wire or flat fence.

2 $\frac{1}{4}$ "W	PEG006
--------------------	--------

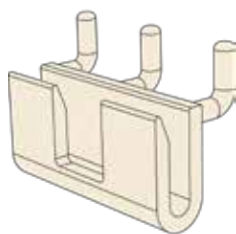

Pegboard/Slatwall U-Hook - Clear

Used to hang items from pegboard or slatwall. Moulded in clear polycarbonate.

2¼"W

PEG004



Shelf Management Mat



Large Interlocking Pusher Tray



Standard Interlocking Tray

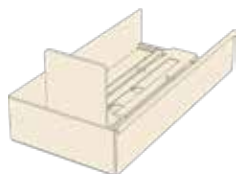

Large Interlocking Pusher Tray

Ideal for pushing bagged pasta/salad. Each tray interlocks to each other. Decal can be affixed to the front fence for product information. Length of tray can be customized from 12" - 22".

Kit Includes:

- 1 - 6 ¾" Wide Tray
- 1 - Heavy Duty 14" Pusher with Spring
- 1 - 3" High Front Fence
- 1 - Back Rail

6¾"W

LARINTRAY00114



Standard Interlocking Tray

Great idea for organizing bottles, yogurt and much more. Specify length when placing order. Available in white and custom colours available (minimum order required).

2½"W

SHE2197

3"W

SHE2272

4¾"W

SHE2792

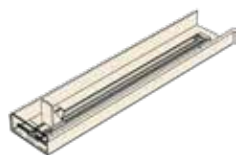

Interlocking Pusher Tray

Ideal for pushing bottled products. Decal can be affixed to the front for product information. Length of tray can be customized from 12" - 16".

Kit Includes:

- 1 - 3" Wide Tray
- 1 - Medium Duty 16" Pusher with Spring
- 1 - 3" High Front Fence
- 1 - Back Rail

3"W

INTERTRAY00116



Shelf Mount Pusher with Dividers

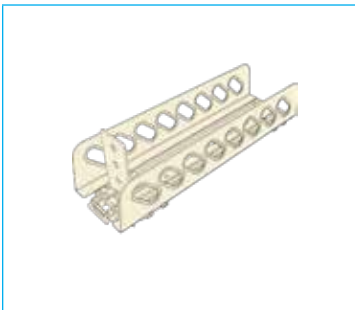

Shelf Mount Pusher with Adjustable Dividers

16"L	SMA616
18"L	SMA618
20"L	SMA620
22"L	SMA622

Hook Pushers



How It Works: Single Hook Snap-On Pusher

Our patented Snap-On Hook Pushers convert your existing pegboard hooks into pushers that keep merchandise upfront and facing forward.

1 Secure top and bottom of pusher backer to base of hook

2 Secure spring base to front of hook

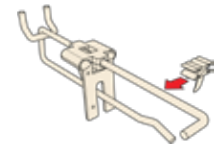
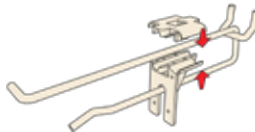
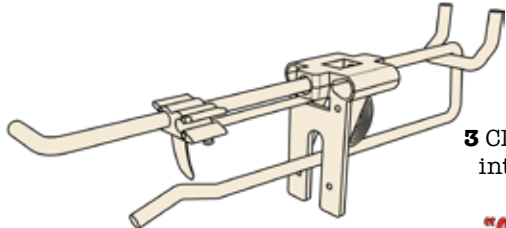

3 Click Spring Base into place

4 Pull Pusher Spring towards front

5 Loop hole in spring over peg on spring base

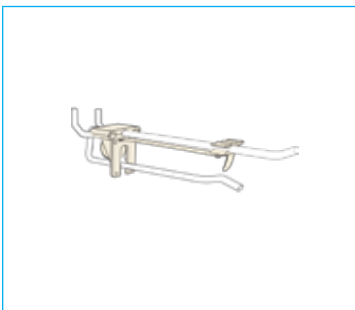
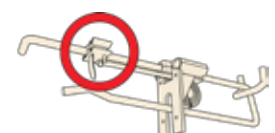
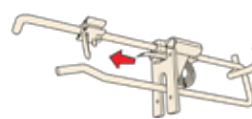

Single Hook Snap-On Pusher

Fits most medium and heavy duty double hooks. Spring weight is subject to products being pushed.

US Patent #7566037B2

PSH0010



Loop Hook Snap-On Pusher

Fits most medium and heavy duty double hooks. Spring weight is subject to products being pushed.

US Patent #7566037B2

PLH011

CD/DVD Pusher

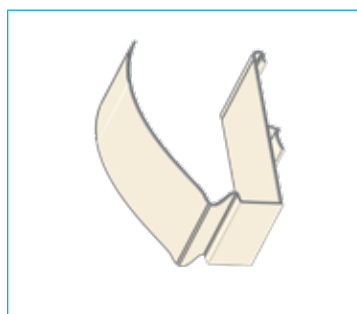

Extruded CD / DVD / Video Game Pusher

Mounts to wire, corrugate and plastic. Ideal for CDs, DVDs and video games. Available in black.

SHE2325

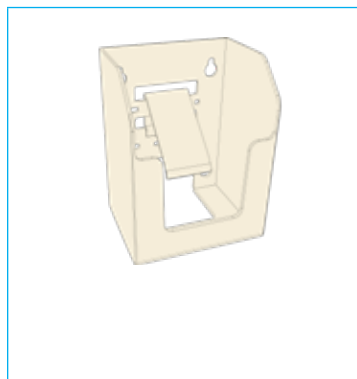

DVD / Video Games Pusher Box

The Front Loading Pusher ensures DVDs and Video Games are always upfront and tidy. It has a 6 DVD capacity and mounting options include suction cup, shelf, pegboard and slatwall.

7¾" H x 5⅞" W

DVDB100



Versa Pusher Clip

Clips onto almost any flat edge. Pushes light weight products upfront to keep them visible. Manufactured in clear PVC. Various lengths available.

SHE2796CLEAR

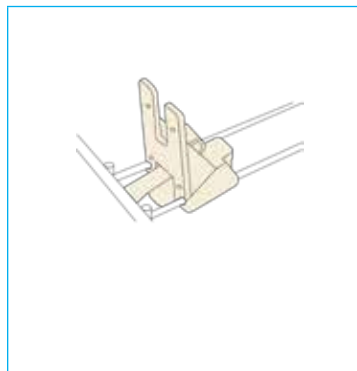

Wire Shelf Snap-On Pusher

Our Wire Shelf Snap-On Pushers keep products front facing.

HKPSHAB

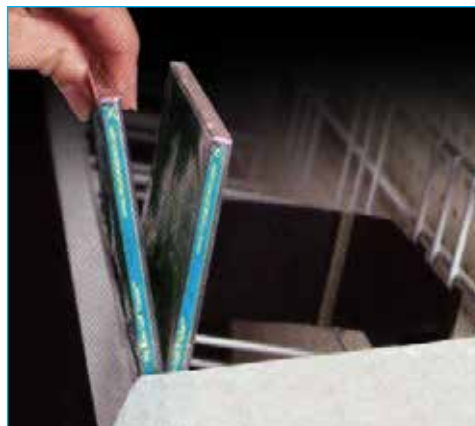
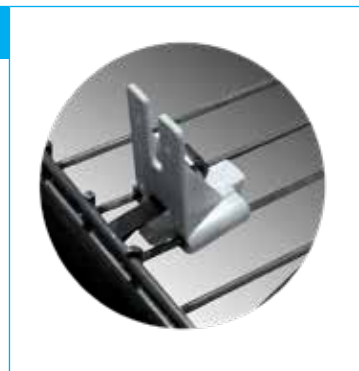

Extruded CD/DVD Pusher

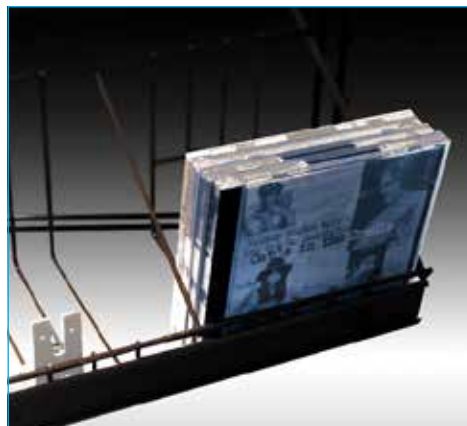

Wire Shelf Snap-On Pusher

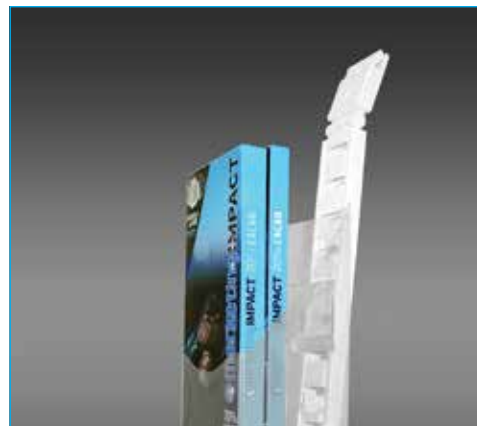

Versa Pusher Clip



How It Works: Extruded Gravity Feed and Pusher Systems

- Low friction extruded PVC track allows product to glide smoothly
- Fully compatible with all our modular pusher system fronts and fences
- Tracks can be cut to custom lengths

1 Choose a Front

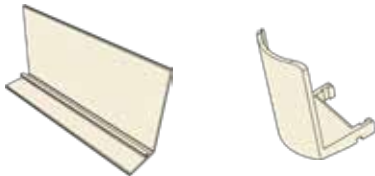

CLEARFENCE148
Clear Front Fence

BTNFRONT
Bottle Pusher Front



2 Choose a Track and Length

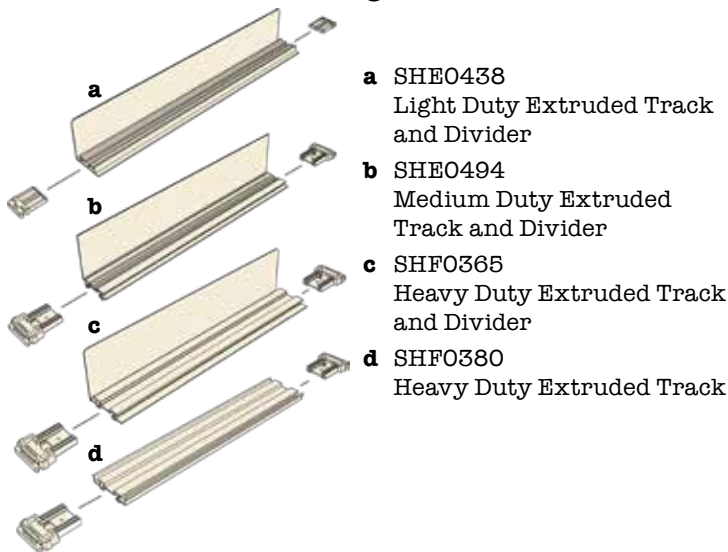

- a** SHE0438
Light Duty Extruded Track and Divider
- b** SHE0494
Medium Duty Extruded Track and Divider
- c** SHF0365
Heavy Duty Extruded Track and Divider
- d** SHF0380
Heavy Duty Extruded Track

3 Add a Divider or End Cap

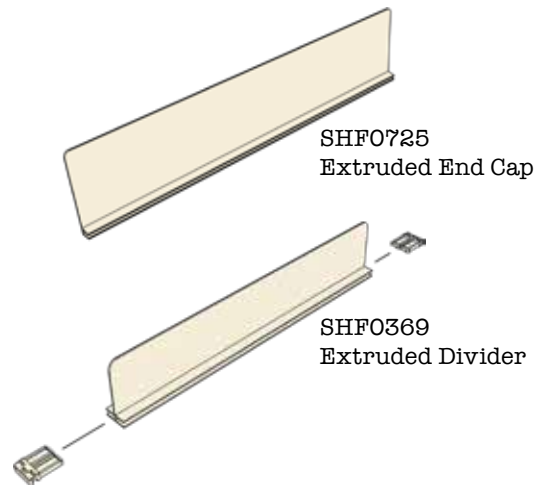

SHF0725
Extruded End Cap

SHF0369
Extruded Divider

4 Choose a Paddle If Using Pushers or Custom Wedge For Gravity Slide Setup

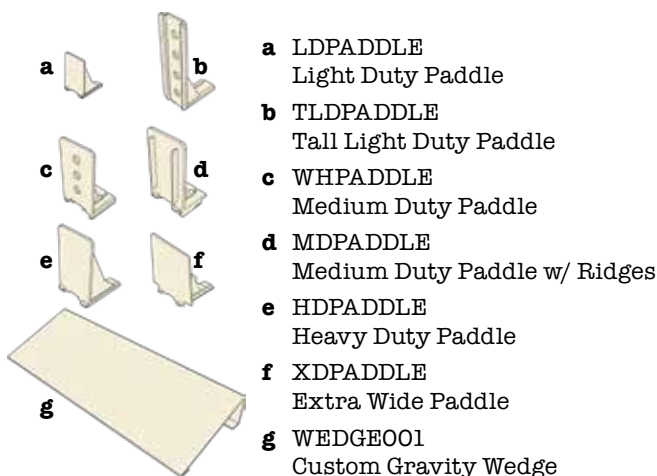

- a** LDPADDLE
Light Duty Paddle
- b** TLDPADDLE
Tall Light Duty Paddle
- c** WHPADDLE
Medium Duty Paddle
- d** MDPADDLE
Medium Duty Paddle w/ Ridges
- e** HDPADDLE
Heavy Duty Paddle
- f** XDPADDLE
Extra Wide Paddle
- g** WEDGE001
Custom Gravity Wedge

Examples of Pusher and Gravity Slide Systems



Extruded Gravity Feed/Pusher System Parts

	<p>Light Duty Extruded Track and Divider</p> <p>Our Light Duty Extruded Tracks are low-friction, fully customizable and inexpensive. Designed to be used with our Pusher and Gravity systems, each track includes Small Adaptors to fasten it to store shelves. They're perfect for pushing or sliding small, lightweight products like spices and are made from clear extruded PVC. Custom lengths and colours are available (minimum order required).</p> <p>2¼"H x 1¾"W SHE0438</p>
---	--

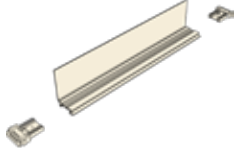
	<p>Medium Duty Extruded Track and Divider</p> <p>Our Medium Duty Extruded Tracks are low-friction, fully customizable and inexpensive. Designed to be used with our Pusher and Gravity systems, each track includes Large Adaptors to fasten it to store shelves. They're perfect for pushing or sliding pharmaceutical products and are made from clear extruded PVC. Custom lengths and colours are available (minimum order required).</p> <p>3½"H x 2¼"W SHE0494</p>
---	--

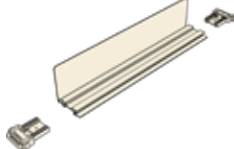
	<p>Heavy Duty Extruded Track and Divider</p> <p>Our Heavy Duty Extruded Tracks are low-friction, fully customizable and inexpensive. Designed to be used with our Pusher and Gravity systems, each track includes Large Adaptors to fasten it to store shelves. They're perfect for pushing or sliding larger items like beverages and are made from clear extruded PVC. Custom lengths and colours are available (minimum order required).</p> <p>3¾"H x 2¾"W SHF0365</p>
---	--





	<p>Heavy Duty Extruded Track</p> <p>Low cost, low friction, and fully customizable our Extruded Tracks can be used for either a Pusher or Gravity Slide System. Each custom track length comes complete with Large Adaptors for secure fastening to store shelves. Add our Extruded T-Dividers between each track to adjust the width to fit your product. Manufactured from clear extruded PVC. Custom lengths and colours are available (minimum order required).</p> <p>2¾"W SHF0380</p>
---	---



DrinkPusher System

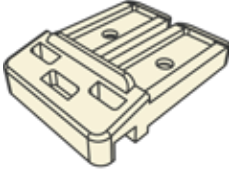

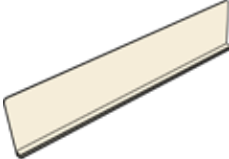
Extruded Pusher System

	<h3>Small Adapter Clips</h3> <p>For use with our Medium and Heavy Duty Tracks. Moulded in clear polycarbonate.</p> <p style="text-align: right;">ADAEPS001</p>												
	<h3>Large Adapter Clips</h3> <p>For use with our Medium and Heavy Duty Tracks. Moulded in clear polycarbonate.</p> <p style="text-align: right;">ADAEPL001</p>												
	<h3>Clear Front Fence</h3> <p>Affix to the front of a shelf. Can be used with our Pushers and Dividers.</p> <table border="1" data-bbox="462 840 1510 1008"> <tr> <td>1¼"H x 47⅞"W</td> <td>With holes</td> <td>CLEARFENCE148</td> </tr> <tr> <td>2"H x 47⅞"W</td> <td></td> <td>CLEARFENCE248</td> </tr> <tr> <td>2½"H x 47⅞"W</td> <td></td> <td>CLEARFENCE2548</td> </tr> <tr> <td>3"H x 47⅞"W</td> <td></td> <td>CLEARFENCE348</td> </tr> </table>	1¼"H x 47⅞"W	With holes	CLEARFENCE148	2"H x 47⅞"W		CLEARFENCE248	2½"H x 47⅞"W		CLEARFENCE2548	3"H x 47⅞"W		CLEARFENCE348
1¼"H x 47⅞"W	With holes	CLEARFENCE148											
2"H x 47⅞"W		CLEARFENCE248											
2½"H x 47⅞"W		CLEARFENCE2548											
3"H x 47⅞"W		CLEARFENCE348											
	<h3>Extruded End Cap</h3> <p>Complete your Light, Medium or Heavy Duty Extruded Track and Divider system with an Extruded Divider. Manufactured from clear extruded PVC. Custom sizes and colours available (minimum order required).</p> <p style="text-align: right;">½"H x 2¼"D SHF0725</p>												
	<h3>Extruded Divider</h3> <p>Use with our Heavy Duty Extruded Track to adjust it to fit your product's width. Each custom length Divider comes with Small Adaptors to secure it to store shelves. Manufactured from clear extruded PVC. Custom sizes and colours available (minimum order required).</p> <table border="1" data-bbox="462 1533 1510 1659"> <tr> <td>2¼"H</td> <td>Light Duty</td> <td>SHF0369</td> </tr> <tr> <td>3½"H</td> <td>Medium Duty</td> <td>SHF0369M</td> </tr> <tr> <td>3¾"H</td> <td>Heavy Duty</td> <td>SHF0369H</td> </tr> </table>	2¼"H	Light Duty	SHF0369	3½"H	Medium Duty	SHF0369M	3¾"H	Heavy Duty	SHF0369H			
2¼"H	Light Duty	SHF0369											
3½"H	Medium Duty	SHF0369M											
3¾"H	Heavy Duty	SHF0369H											
	<h3>Custom Gravity Wedge</h3> <p>Our Custom Gravity Wedge is built to suit your custom Slide-and-Divide Gravity System and turns a flat shelf into an angled one. Specify dimensions when ordering. Fabricated from expanded PVC. Available in white and custom colours (minimum order required).</p> <p style="text-align: right;">WEDGE001</p>												

	<p>Light Duty Paddle</p> <p>This Paddle works with our Light and Medium Duty Extruded Tracks.</p> <p>1½"H x ⅞"W LDPADDLE</p>
	<p>Tall Light Duty Paddle</p> <p>This paddle works with our Light and Medium Duty Extruded Tracks.</p> <p>4½"H x 1⅝"W TLDPADDLE 4½"H x 1⅝"W TLDPADDLEANG</p>
	<p>Medium Duty Paddle</p> <p>This Paddle works with our Heavy Duty Extruded Tracks.</p> <p>4½"H x 2⅜"W WHPADDLE</p>
	<p>Medium Duty Paddle with Ridges</p> <p>This Paddle works with our Heavy Duty Extruded Tracks.</p> <p>4"H x 2⅜"W MDPADDLE</p>
	<p>Heavy Duty Paddle</p> <p>This Paddle works with our Heavy Duty Extruded Tracks.</p> <p>4½"H x 3⅛"W HDPADDLE</p>
	<p>Extra Wide Paddle</p> <p>This paddle works our Extruded Tracks and regular Pushers. It's ideal for pushing bagged salad or other wide products.</p> <p>4"H x 4½"W XDPADDLE</p>



Pusher Fronts & Paddles

We carry an assortment of pushers and paddles so you can configure your pusher system to support a wide variety of merchandise.



Finger Pusher Front - CLRFRNT005



Bottle Pusher Front - BTNFRONT

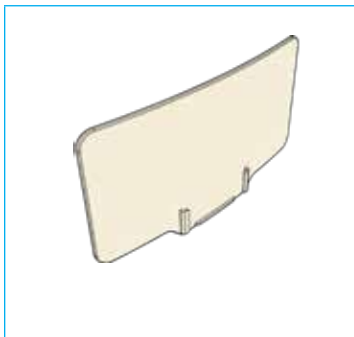

Pusher Front - Curved

The Curved Pusher Front can be attached to our Multi-Use Heavy Duty, Multi-Use Medium Duty and Kwickload® Pusher Systems. It's Ideal for bagged products. Moulded in clear polycarbonate.

3½"H x 7"W

CLRFRNT007

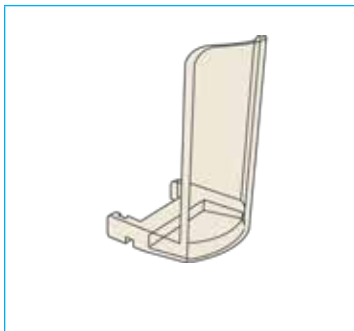

Pusher Front - Bottle

The Bottle Pusher Front can be attached to our Multi-Use Heavy Duty, Multi-Use Medium Duty and Kwickload® Pusher Systems. Manufactured in clear polycarbonate.

3⅞"H x 2⅜"W

BTNFRONT

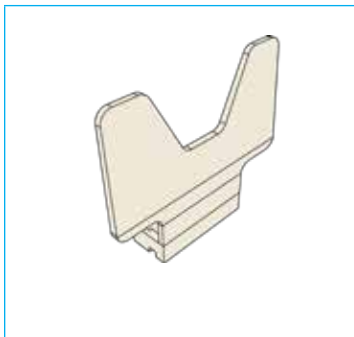

Pusher Front - Clear

The Clear Pusher Front can be attached to our Multi-Use Heavy Duty, Multi-Use Medium Duty and Kwickload® Pusher Systems. Manufactured in clear polycarbonate.

4½"H x 3¾"W

CLRFRNT001



Small Pusher Front - Clear

The Small Clear Pusher Front works with our Kwickload® pusher system. Manufactured in clear polycarbonate.

3¼"H x 3"W

CLRFRNT003

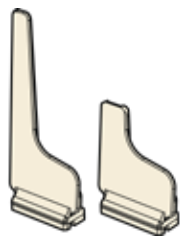

Pusher Front - Finger

The Finger Pusher Fronts can be attached to our multi-use heavy and medium duty pusher systems and Kwickload® Pusher Systems. Manufactured in clear polycarbonate.

6¾”H x 3”W	Tall	CLRFRNT005
3½”H x 3”W	Short	CLRFRNT010

Extruded Gravity Feed/Pusher System Kits

Our new Slide-and-Divide merchandising system is the gold standard for gliding racks. It uses cost-effective extrusion technology and injection moulding to create a durable modular system that can be extruded to any length, with dividers walls incorporated into every track. Width is adjusted by simply adding more tracks. As well, the tracks are fully compatible with our existing pushers, giving you lot of ways to customize your setup to match your merchandising needs.

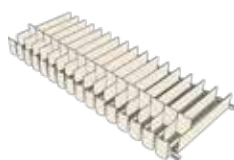

Drink Pusher System - 16” Deep

- Pusher Kit Includes:
- 16 - 16” Deep Pushers with Springs
 - 17 - Bottle Fronts
 - 1 - End Divider
 - 2 - Basic Rails 4’L

HSLP416C



Drink Gravity System - 16” Deep

- Gravity Kit Includes:
- 17 - Bottle Fronts
 - 1 - End Divider
 - 2 - Basic Rails 4’L
 - 17 - Heavy Duty Track Dividers

HSL417C



Condiment Gravity System - 16” Deep

- Gravity Kit Includes:
- 10 - Medium Duty Extrude Track Dividers
 - 1- 3”H Clear Fence
 - 1 - Rear T-Snap
 - 1 - End Divider

HSL410C

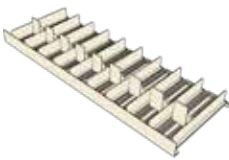

Condiment Gravity System - HSL4100

	<h3>Condiment Pusher System - 16" Deep</h3> <p>Pusher Kit Includes:</p> <ul style="list-style-type: none"> 9 - 16" Deep Pushers with Springs 1 - 3"H Clear Fence 1 - Rear T-Snap 1 - End Divider <p style="text-align: right;">MSLP409C</p>
---	---

	<h3>Spice Pusher System - 16" Deep</h3> <p>Pusher Kit Includes:</p> <ul style="list-style-type: none"> 24 - 16" Deep Pushers with Springs 1 - 1 1/4" H Clear Fence 1 - Back Rail 4'L 1 - End Divider <p style="text-align: right;">L5LP424C</p>
---	---

	<h3>Spice Gravity System - 16" Deep</h3> <p>Gravity Kit Includes:</p> <ul style="list-style-type: none"> 1 - 1 1/4" H Clear Fence 1 - Back Rail 4'L 1 - End Divider 17 - Heavy Duty Track Dividers <p style="text-align: right;">L5L425C</p>
--	--

<div style="background-color: red; color: white; padding: 2px; font-weight: bold;">NEW</div> 	<h3>Double Pusher Tray Rack</h3> <p style="text-align: right;">DBLMODRACK</p>
--	---



Double Pusher Tray Rack - DBLMODRACK



Double Pusher Tray Rack - DBLMODRACK



Loss Prevention

Innovative Loss Prevention solutions tailored to meet your needs



How It Works: Loss Prevention

Answer these questions to help determine which loss prevention solution best meets your needs.

1. What's the width of your shelf?
2. What's the depth of your shelf?
3. What are the dimensions of the individual product?
4. What's the weight of the individual product and how many will fit in a row on the shelf?
5. Do you need a security door to control access to the products on the shelf?
6. Do you need a sliding door mechanism to limit product access to one at a time?

LOCKMG002: Lock Box



INWISECLI001: Secure Slide Shelf with SlideGuard



SECSYS001G2: Secure Merchandiser Shelf



Secure Merchandiser Shelf

Secure Merchandiser shelf is available in 24", 36", 48" widths and 12", 14" and 16" depths. Specify width and depth when ordering.

Kit Includes:

- 11 - Pushers
- 11 - Easy Lift Handles
- 10 - Dividers
- 10 - Panel Sliders
- 2 - Basic T-Snap bars
- 1 - Slider Shelf with Metal Topper
- 1 - Alarm

48"W X 16"D

SECSYS001G2



Secure Merchandiser Slide Shelf with SlideGuard

Kit Includes:

- 1 - 4' Metal Slider Shelf with Metal Topper
- 1 - Front Label Holder
- 10 - SlideGuard Panel Sliders
- 11 - Pushers
- 10 - Dividers
- 1 - Basic Snap Rails
- 1 - 3" Front
- 1 - High Security Lock

Secure Merchandiser Shelf
with SlideGuard

INWISECLI001





The Secure Merchandiser's alarm sounds when its door is opened



The Secure Merchandiser is patented in the USA and Canada



Pull-Out Shelf Pusher Kit with Slide Mechanism

Complete system with pull-out slide mount for easy restocking. Fits 16" deep store shelves.

Kit Includes:

- 11 - Heavy Duty Pusher
- 10 - Dividers
- 1 - 3" Front Fence (48"L)
- 2 - Metal Side Gables Mounted to a 48" Sliding Metal Shelf
- 1 - Basic T-Snap bar

Pull-Out Shelf Pusher Kit with Slide Mechanism CARTSLIDESHELF

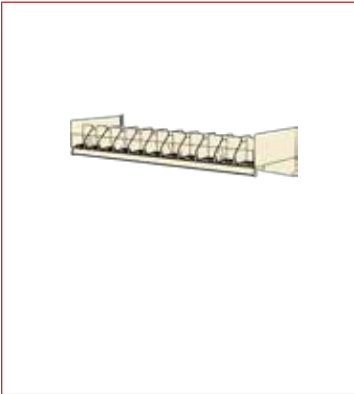

Shelf Pusher Kit

Fits standard store shelf widths and depths.

Kit Includes:

- 11 - Heavy Duty Pushers
- 10 - White Dividers
- 2 - Metal Side Gables
- 1 - 3" Clear Front Fence
- 1 - Basic Snap Rail

Shelf Pusher Kit RAZORSHELF



Security Flip Door with Alarm

The Security Flip Door fits a standard shelf width of 48". It can also be used with our Pusher Kits. Manufactured in Co-Poly. Custom sizes available (minimum order required).

Security Flip Door with Alarm SECURITY DOOR



Lock Box

Lock box features slide-and-hide door mechanism that stows away for easy access to products.

48"W x 16"D	Lock Box with Metal Gables (Single Lock)	LOCKMG001
48"W x 16"D	Lock Box with Metal Gables (Double Lock)	LOCKMG002
48"W x 16"D	Lock Box with CoPoly Gables (Single Lock)	LOCK001
48"W x 16"D	Lock Box with Co-Poly Gables (Double Lock)	LOCK002



Security Flip Door with Gum Pusher Kit



Security Flip Door with Adjustable Dividers

SlideGuard System

The SlideGuard System is a revolutionary approach to retail loss prevention, combining great product visibility with an effective theft deterrent. The SlideGuard System is available in styles to protect products on perforated shelving, peg hooks and pusher systems.



SlideGuard System



SlideGuard System



SlideGuard System



SlideGuard Standard Kit with Pushers - 16" Deep

Fits 16" deep shelves. High-impact clear plastic SlideGuard panels are available in 4 sizes. Specify panel size when ordering. Kit includes:

- 1 - SlideGuard Hardware Kit
- 1 - SlideGuard Panel Kit
- 1 - 3" Front Fence
- 1 - Basic T-Snap bar
- 10 - Dividers
- 9 - Pushers with springs

SlideGuard Standard Kit with Pushers

INVISIKIT001

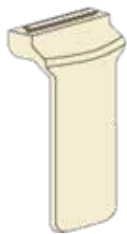

SlideGuard Panel Kit

SlideGuard Panels are made of High-impact clear plastic and feature a clicking mechanism to alert store associates of potential theft. Choose the panel size that matches the width of your product.

3½"H x 4"W	11 pieces / bag	PANEL001
5½"H x 3"W	15 pieces / bag	PANEL002
5½"H x 4"W	11 pieces / bag	PANEL003
8"H x 4"W	11 pieces / bag	PANEL004

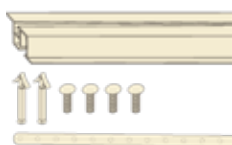

SlideGuard Hardware Kit

- Kit Includes:
- 4 - Screws
 - 2 - Installation Pins
 - 1 - 48" Ratcheting Slide Bar

PANELKIT48



Hanging Retailers

The most comprehensive and versatile hanging systems in the industry.

The MAX Hanging Merchandising System

Cross-merchandise any product, maximize selling space, add signage and watch sales soar!



How It Works: The Max Mounting Options and Applications

The MAX can be hung in a variety of ways, including connecting it to another MAX for greater length. It holds a variety of standard hooks which you can position to accommodate the size of the product being hung from it.

- a** From a shelf bracket
- b** Using our MAX Hanger
- c** From a wire bin or sidewinder
- d** With a self-centring mount
- e** Adding sign holder frames
- f** With the MAX cardholder
- g** Linked to another MAX
- h** From expandable brackets

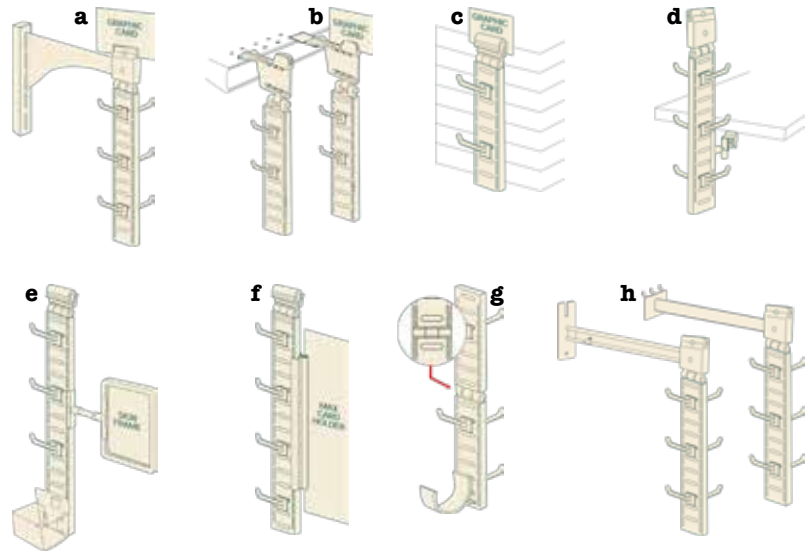

The MAX

Meet the MAX - your solution for turning empty space into a profit centre!

The MAX comes in 10", 20" and 30" lengths and includes hangers on both ends. One end can mount to a shelf and the other to a wire. Use with our Adhesive Hang-Tabs to hang almost product from a hook.

10"L	White	MAXWHITE10
20"L	White	MAXWHITE20
30"L	White	MAXWHITE30

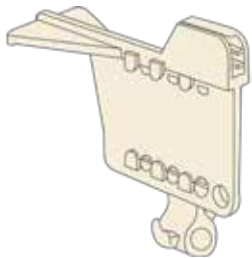

The MAX Hanger

Can be moulded in coloured high-impact styrene or clear polycarbonate. The MAX Hanger connects The MAX to a perforated shelf. Sports a sign holder on top for graphics or a price card. Custom colours available (minimum order required).

Beige	MAXHANGERBG
Black	MAXHANGERBK
Clear	MAXHANGERCLR

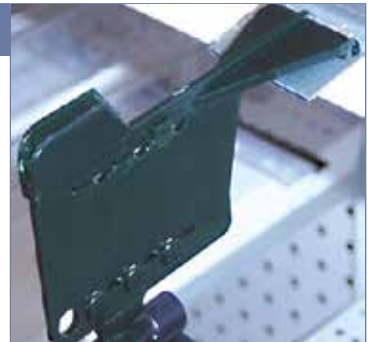

The Extended MAX Hanger

Can be moulded in coloured high-impact styrene or clear polycarbonate. Attaches under a shelf with screws. Connects The MAX to a perforated shelf. Sports a sign holder on top for graphics or a price card. Custom colours available (minimum order required).

Clear	EXTMAXCL
Beige	EXTMAXBG
White	EXTMAXWH
Black	EXTMAXBK



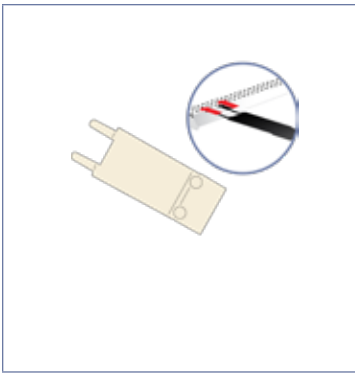

The MAX Extension Bracket

Extend the MAX further into the aisle for maximum exposure. Available in black and white. Custom colours also available (minimum order required).

2"L	MAXBRACKET2
4"L	MAXBRACKET4
6"L	MAXBRACKET6



NEW

Shelf-Top Hook for Flag or Flush Merchandising

Securely hang merchandising strips from most perforated metal shelf holes. Two styles to choose from: "flag" which holds strips perpendicular (vertical) to the shelf front, and "flush" which holds strips parallel (horizontal) to the shelf front. Made of 0.135" diameter zinc plated steel wire.

3½"W	Flag	ACC201FLAG
4"W	Flush	ACC201FLUSH

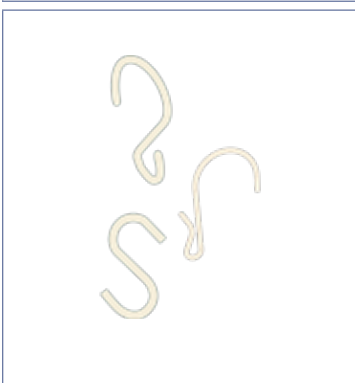

Strip Retailer Mounting Hooks

Lets you hang a Strip Retailer almost anywhere to merchandise products. 0.080" diameter nickel plated wire.

S-Hook Loop	Open Style	ACC002
S-Hook Loop	Crimped Style	ACC002P
S-Hook		ACC004



NEW

Double Hanging Extension Bracket



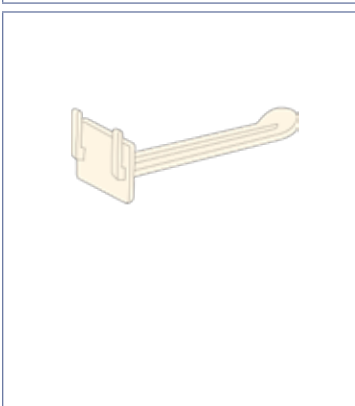



1"H x 1½"W x 9"D	SHE4736
------------------	---------

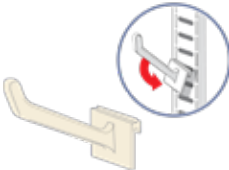

The MAX Butterfly Hook

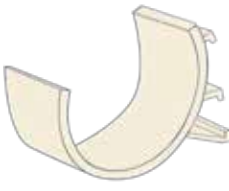
This hook holds packages with butterfly and delta holes. Available in white.

4"L	MAXBHOOK04
5"L	MAXBHOOK05
6"L	MAXBHOOK06

	<p>The MAX Hook</p> <p>Designed specifically for use with The MAX.</p> <table border="1"> <tr> <td>¾”L</td> <td>MAXHOOK3/4</td> </tr> <tr> <td>2”L</td> <td>MAXHOOK2</td> </tr> <tr> <td>3”L</td> <td>MAXHOOK3</td> </tr> <tr> <td>4”L</td> <td>MAXHOOK4</td> </tr> </table>	¾”L	MAXHOOK3/4	2”L	MAXHOOK2	3”L	MAXHOOK3	4”L	MAXHOOK4
¾”L	MAXHOOK3/4								
2”L	MAXHOOK2								
3”L	MAXHOOK3								
4”L	MAXHOOK4								
	<p>The MAX Card Holder - Clear</p> <p>One side snaps onto the edge of The MAX. The other side has a gripper to hold graphics. Custom colours available (minimum order required).</p> <table border="1"> <tr> <td>3”L</td> <td>MAXCARDHOLDER</td> </tr> </table> 	3”L	MAXCARDHOLDER						
3”L	MAXCARDHOLDER								
	<p>The MAX Bottle Holder - Clear</p> <p>A special hook designed for holding bottles with the MAX. Custom sizes available (minimum quantities required).</p> <table border="1"> <tr> <td>Clear</td> <td>MAXACC001</td> </tr> </table> 	Clear	MAXACC001						
Clear	MAXACC001								
	<p>The MAX Bracket for Warehouse Uprights</p> <p>Mounts to standard uprights. Tightens with a screw and wing nut. Available in black, clear, red and white. Specify colour when placing order.</p> <table border="1"> <tr> <td></td> <td>MAXWHBRACKET</td> </tr> </table> 		MAXWHBRACKET						
	MAXWHBRACKET								
	<p>The MAX Pegboard and Slatwall Bracket</p> <p>Mounts to standard uprights, extending 16” and putting The MAX beyond the shelf and product. Tightens with a screw and wing nut.</p> <table border="1"> <tr> <td></td> <td>MAXSHELBRACKET</td> </tr> </table>		MAXSHELBRACKET						
	MAXSHELBRACKET								

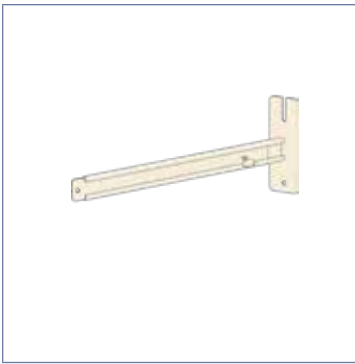

The MAX Universal Bracket

Mounts to standard uprights, extending The MAX beyond the shelf and product. Extends 12" - 23" in length. Tightens with a screw and wing nut.

MAXSLBRACKET



The MAX Counter Spinner

The three-sided MAX Spinner increases the products you can display three times. The MAX Spinner is designed to mount to various bases and extension arms, placing your product in a wide range of areas.

MAXSPINNER

Strip Retailers & Accessories

How It Works: Heavy Duty Moulded Strip Retailers

Strips include an interchangeable graphic holder moulded in durable polyethylene.



Strips can be snapped together to form double-sided strips of 24 clips.

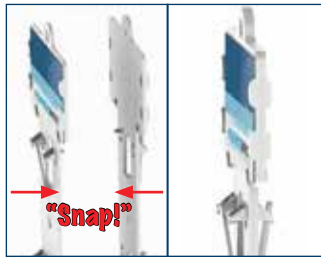

Strips can also be snapped together end-to-end to form longer strips.



Heavy Duty Moulded Strip Retailers

Twelve hooks with label area. Products clip onto strips. Can become a double sided strip retailer. Label area 1½"H x 2¾"W

28⅞"L	Black	SCR00325B
28⅞"L	White	SCR00325W
28⅞"L	Natural	SCR00325N



Heavy Duty Moulded Strip Retailers



Light Duty Strip Retailer



Standard Strip Retailer



Light Duty Strip Retailer - 12 Clip

Products attach with ease. Made of HDPE.

22" L	SCR00422L
28" L	SCR00428L



Standard Strip Retailer

Products can be hooked or clipped on. Available in six or twelve clips, with or without adhesive.



3/4"W x 16 1/2"L	6 Clips	SCR00516
3/4"W x 32 1/2"L	12 Clips	SCR00712
2 3/4"W x 1 1/4"H	Header	SCR007DHR



Hanging Wand Retailer

Designed for heavier merchandise. Steel with beige enamel finish.



No Header / Beige	12 Clips	SCR00222BEIGE
-------------------	----------	---------------

Locking Strip Retailer with Header

Injection moulded with twelve hooks. Extremely durable, loads easily and locks for secure shipment. Header measures 1 3/8"H x 3"W. Strip measures 1 1/8"W.

24 1/2" w/ Header	Hooks 2" apart	SCR00624H
30" w/o Header	Hooks 2 1/2" apart	SCR00630H











Single-Sided Strip Retailer

Consists of six closing hooks. Each strip is designed to lock into another strip, creating continuous lengths. Available with or without self-adhesive tape.

3/4"W x 6 1/2"L	w/ Adhesive	SCR00506A
3/4"W x 6 1/2"L	w/o Adhesive	SCR00506



	<p>Double-Sided Strip Retailer - With and Without Header</p> <p>Twelve hooks injected moulded for durability. Loads easily and locks for secure shipment. Header measures 1 3/8" H x 3 1/2" W. Strip measures 1 1/8" W. Available in 24 1/4" and 30" lengths.</p> <table border="1"> <tr> <td>24 1/4" L w/ Header</td> <td>Hooks 2" apart</td> <td>SCR00625H</td> </tr> <tr> <td>22 1/4" L w/o Header</td> <td>Hooks 1 7/8" apart</td> <td>SCR00624</td> </tr> </table>	24 1/4" L w/ Header	Hooks 2" apart	SCR00625H	22 1/4" L w/o Header	Hooks 1 7/8" apart	SCR00624	
24 1/4" L w/ Header	Hooks 2" apart	SCR00625H						
22 1/4" L w/o Header	Hooks 1 7/8" apart	SCR00624						
	<p>Double-Sided Strip Retailer - 12 Clip</p> <p>Closing hooks for back-to-back display. Header measures 1 1/4" H x 2 1/8" W. Strip measures 14" L.</p> <table border="1"> <tr> <td>1 1/4" H x 2 1/8" W</td> <td>SCR00800</td> </tr> </table>	1 1/4" H x 2 1/8" W	SCR00800					
1 1/4" H x 2 1/8" W	SCR00800							
	<p>Durable Vinyl Pouch Strip Retailer</p> <p>Pockets are custom made to fit your product. Perfect for boxes, bottles, tubes and more. Top pocket for graphics or price card. Custom sizes available.</p> <table border="1"> <tr> <td>Up to 30" Long</td> <td>SCR10008</td> </tr> </table>	Up to 30" Long	SCR10008					
Up to 30" Long	SCR10008							
	<p>Adhesive Display Strip</p> <p>Twelve square adhesive display retailer for light weight packages.</p> <table border="1"> <tr> <td>1 3/8" W x 19 3/4" L</td> <td>SCR0012</td> </tr> </table>	1 3/8" W x 19 3/4" L	SCR0012					
1 3/8" W x 19 3/4" L	SCR0012							

How It Works: Custom Clip Strips

- Made from durable, tear-free material allowing the unit to last in the retail environment.
- The clip design securely holds the product to the strip, allowing it to be prepacked.
- Can be printed single or double sided to maximize brand presence.
- Simple and efficient design makes Custom Clip Strips an extremely cost effective merchandising tool.
- Strip shape and clip can be customized (minimum order required).



How It Works: Gift Card Extender Uses

Use the Gift Card Extender with The MAX or use the Double Clip to hang two strip retailers. You can even attach a header graphic to it. Double sided graphics can also be displayed using our integrated card clips.

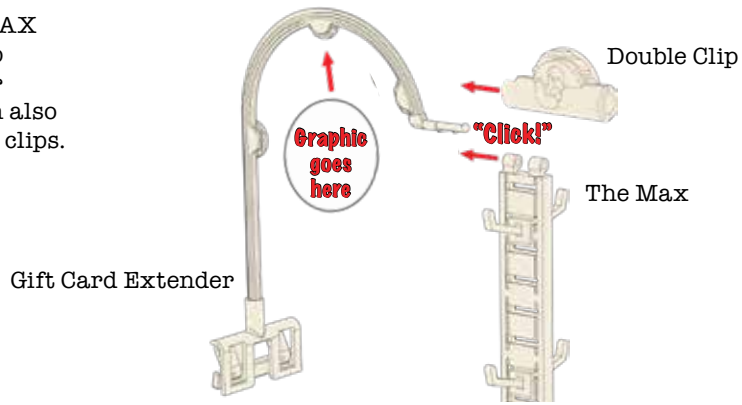

Gift Card Hanger

The Gift Card Hanger lets product hang directly from a hook for an interesting free-floating effect. The unique base can mount to most wire and flat fences and is made from polycarbonate, so it's durable and economical. It's ideal for gift cards and cross merchandising. Fits most wire and flat fences. Moulded in polycarbonate. Available in clear, white and black. Custom colours also available (minimum order required).

GIFTHOOK



Gift Card Extender

Fits most wire and flat fences. Moulded in polycarbonate. Available in clear, white and black. Custom colours also available (minimum order required).

Clear	GIFTEXTCL
White	GIFTEXTWH
Black	GIFTEXTBK



The Wobbler

The Wobbler – Glass Mount	Clear	WOBBLERCL-GLASS
The Wobbler – Slatwall Mount	Clear	WOBBLERCL-SLAT
The Wobbler – Gondola Mount	Clear	WOBBLERCL-GON
The Wobbler – Pegboard Mount	Clear	WOBBLERCL-PEG



Gift Card Extender - GIFTEXTWH



The Wobbler - WOBBLERCL-PEG









Gift Card Extender with Graphic Insert

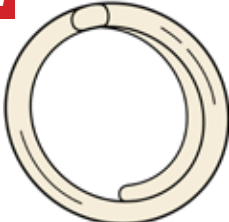

Display Components

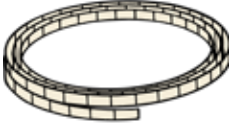
From Hooks to Hang Tabs, we carry everything you need to build effective and eye-catching retail displays.

	<p>Split Ring</p> <p>Easy to close, one-piece design. 5/8" ID. White split ring is manufactured in polyethylene. Clear split ring manufactured in plastic.</p> <table border="1"> <tr> <td>Clear</td> <td>ACC270C</td> </tr> <tr> <td>White</td> <td>ACC270W</td> </tr> </table>	Clear	ACC270C	White	ACC270W	
Clear	ACC270C					
White	ACC270W					
<p>NEW</p> 	<p>Plastic Spiral Ring</p> <p>Overlap spiral design for ease of use and memory closure. Perfect for hanging signs from wire fixtures. Made of 0.094" diameter rigid PVC material. Available in clear and white. Packaged 250 per bag</p> <table border="1"> <tr> <td>Clear</td> <td>ACC276C</td> </tr> <tr> <td>White</td> <td>ACC276W</td> </tr> </table>	Clear	ACC276C	White	ACC276W	
Clear	ACC276C					
White	ACC276W					
<p>NEW</p> 	<p>Plastic Overlap Ring</p> <p>Split ring style design for ease of use and memory closure. Perfect for hanging signs from wire fixtures. Available in clear and white. Packaged 250 per bag</p> <table border="1"> <tr> <td>Clear</td> <td>ACC277C</td> </tr> <tr> <td>White</td> <td>ACC277W</td> </tr> </table>	Clear	ACC277C	White	ACC277W	
Clear	ACC277C					
White	ACC277W					
	<p>Flexible Magnets</p> <p>Scored magnetic roll of 1,200 magnets, measuring 1/2"W x 1"L. Clear permanent adhesive on back.</p> <table border="1"> <tr> <td>Roll of 1200</td> <td>ACC510</td> </tr> </table>	Roll of 1200	ACC510			
Roll of 1200	ACC510					
<p>NEW</p> 	<p>Magnetic Adapter</p> <p>Ceramic magnet in nickel plated steel housing. Ideal for attaching lightweight signs and display products to shelving and other metal surfaces. 1/8" Diameter centre hole</p> <table border="1"> <tr> <td>1/4"H x 7/8"W x 1"L</td> <td>SHB0301CH</td> </tr> <tr> <td>1/4"H x 7/8"W x 3"L</td> <td>SHB0303CH</td> </tr> </table>	1/4"H x 7/8"W x 1"L	SHB0301CH	1/4"H x 7/8"W x 3"L	SHB0303CH	
1/4"H x 7/8"W x 1"L	SHB0301CH					
1/4"H x 7/8"W x 3"L	SHB0303CH					
<p>NEW</p> 	<p>Magnetic Adapter with D-Tape</p> <p>Ceramic magnet in nickel plated steel housing with D-tape backer. Ideal for attaching lightweight signs and display products to shelving and other metal surfaces. D-tape backing also allows it to be attached to most smooth indoor surfaces. 1/8" Diameter centre hole.</p> <table border="1"> <tr> <td>1/4"H x 7/8"W x 1"L</td> <td>SHB0301DTAPE</td> </tr> <tr> <td>1/4"H x 7/8"W x 3"L</td> <td>SHB0303DTAPE</td> </tr> </table>	1/4"H x 7/8"W x 1"L	SHB0301DTAPE	1/4"H x 7/8"W x 3"L	SHB0303DTAPE	
1/4"H x 7/8"W x 1"L	SHB0301DTAPE					
1/4"H x 7/8"W x 3"L	SHB0303DTAPE					

NEW



Extra Heavy Duty Magnetic Adapter

Extra heavy-duty rectangular zinc-plated casing containing an integrated ceramic magnetic block base. Use to display large format upright signs or heavy display products from metal surfaces such as gondola tops or pallet rack uprights. Mount with screws or common 3/16" pop rivets (not included).

½"H x 1½"W x 3"L

SHB031CH



Adhesive Pad Roll

Double-sided, foam adhesive pads, ¾"W x 2¾"L x ⅛" thick.

Roll of 5000

ACC520



Adhesive Roll

Double-sided foam adhesive roll, ½"W x 1/32" thick.

1 Roll (216')

ACC521P

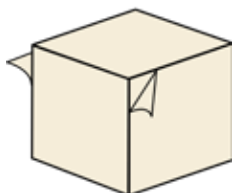

Foam Block Stand-Off

Double-sided foam tape block attaches with permanent adhesive.

1"H x 1"W x 1"D

ACC401



Hook & Loop Fastener Roll

Adhesive-backed roll of Hook & Loop. Measures ⅝"W x 25 yards.

Hook Fastener

VEL002WHH

Loop Fastener

VEL002WHL



Hook & Loop Fastener Button Roll

Adhesive-backed roll of Hook & Loop buttons. Each roll contains 1028 ¾" diameter buttons.

Hook Fastener

VEL003WHH

Loop Fastener

VEL003WHL

	Cable Ties	
	Notched full length, 1/8"W. Made from natural nylon.	
	4"L	TIEWRAPNATLD04
	8"L	TIEWRAPNATLD08
	11"L	TIEWRAPNATLD11

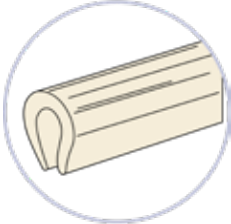
	Edge Protector - Clear	
	Covers unfinished corrugate or plastic display edging. Manufactured in flexible PVC.	
	Clear	SHE0084



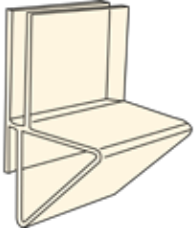

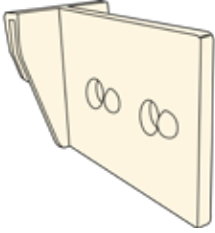

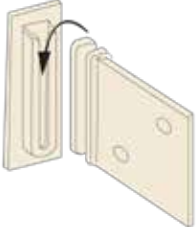

	Shelf Support - Single	
	Shelf support that mounts into 1/8" corrugate material.	
	Shelf Support - Single	SHC047-CC
	Shelf Support - Single	w/ Adhesive SHC047-CC3

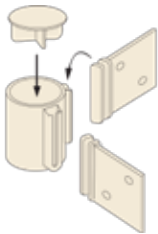
	Shelf Support - Vertical	
	Fits onto 1/8" corrugate. Measures 2" in length.	
	Natural Polypropylene	SCH048

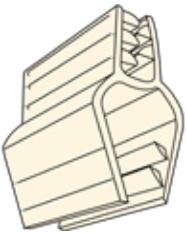
	Shelf Support - Horizontal	
	Measures 2" in length, with teeth on sides on top to securely grip a shelf. Fits onto 1/8" corrugate.	
	Natural Polypropylene	SCH048-HD

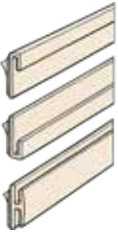
	Shelf Support - Two Piece	
	Two-piece shelf support that attaches to 1/4" corrugate. Manufactured in white polypropylene.	
	1 7/8"H x 2 1/4"L	SHC049

	<p>Shelf Support - Four Sided</p> <p>Allows signs to display four ways with cap to provide finished look. Fits 1 3/4" OD display poles. Holds up to 1/4" corrugate. Manufactured in white polypropylene.</p> <p>2 1/2"H SHC055</p>
	<p>Flexible Hinge</p> <p>Extruded hinge with two 1/2" wide adhesive strips that stick to most flat surfaces. Manufactured in clear PVC.</p> <p>1 1/4"W x 3"L SHE0009CLEAR</p>
	<p>Two-Way Clip with Gripper</p> <p>Two-way clip holds material up to 80pt. thick on one side and 1/8" and 1/4" thick on the other. Manufactured in clear PVC.</p> <p>1"H x 1"W SHC038CLEAR01</p>
	<p>H-Clip with Gripper</p> <p>Attach signs above displays or fixtures. Holds up to 80pt. thick material. Manufactured in Clear PVC.</p> <p>3"L SHC600</p>
	<p>J-Track and H-Track Sign Holders</p> <p>Secures in place with permanent adhesive. Holds material up to 1/4" thick. Clear track measures 48" in length and can be cut down to size. Available in black, white and clear. Custom colours available (minimum order required).</p> <p>J-Track SHE2167CLEAR H-Track SHF6502</p>
	<p>Plastic Turntable</p> <p>Can be attached to displays and fixtures to provide a sturdy base. Manufactured in clear styrene.</p> <p>5 1/2" TUR001 12" TUR005</p>

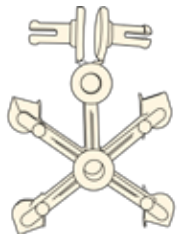

Spider Clip

Mounts to 1¼" shelf channel to display literature boxes, using two dart clips. Made from natural polypropylene.

ACC900

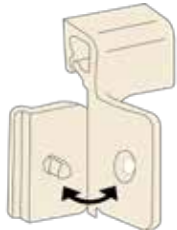

Clip-In Data Strip Fold-N-Hold

Clips onto your sign so that it can be displayed from a data strip. Holds paper signs up to 10pt. thick. Manufactured in natural polypropylene.

SIGN205

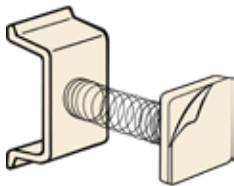

Channel Mount Spring Wobbler

Fits most 1¼" shelf channels. Permanent adhesive holds signs and promotional items. Made of white polypropylene and styrene with 1"L metal spring.

SHC140

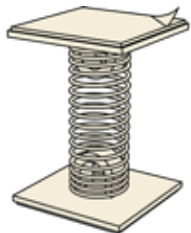

Spring Wobbler

Metal spring with adhesive mount that sticks to any flat surface. Holds signs and promotional items. White styrene with 1" metal spring.

SHC150

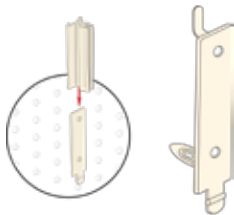

Sign Holder Pegboard Bracket

Attaches sign holders and adaptors to most standard pegboard. 2⅝"H x ¾"W mounting area.

White

PEG010

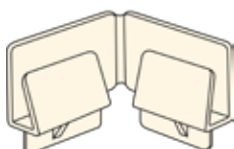

Display Foot

Lifts display ½" off the floor. Holds up to ⅝" corrugate. Manufactured in polypropylene.

DISFOOT



Display Caster



Display Foot



Display Caster

Self-adhesive Casters stick to the bottom of a display, lifting it 3/4" off the floor and making it easier to move around the store.

DISCASTER

Hooks, Hangers & Label Holders

NEW



Corrugated Universal Butterfly Display Hook

Fits 1/8" (B-Flute) corrugated having 1" on centre X-cuts for insertion. Available in White and custom colours (minimum order required)

3" L	HK0133WH
4" L	HK0134WH
5" L	HK0135WH
6" L	HK0136WH
8" L	HK0138WH

NEW

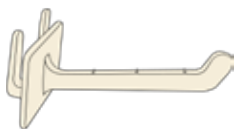

Corrugated Universal Display Hook

Fits 1/8" (B-Flute) corrugated having 1" on centre X-cuts for insertion. Available in White and custom colours (minimum order required)

1 1/4" L	HK0171WH
2" L	HK0172WH
4" L	HK0174WH
6" L	HK0176WH
8" L	HK0178WH





Corrugate Display Butterfly Hook

Attaches to 1/8" corrugate. Holds packages with butterfly and delta holes. Available in white or black.

2" L	HK0137-2
3" L	HK0137-3
4" L	HK0137-4
5" L	HK0137-5
6" L	HK0137-6
7" L	HK0137-7

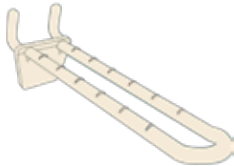
	Double Round Hook	
	Available in white and black. Custom colours also available (minimum order required).	
	1" W x 2" L	HK0222
	1" W x 4" L	HK0224
	1" W x 6" L	HK0226
1" W x 8" L	HK0228	

	Heavy Duty Double Loop Hook	
	Holds packages with butterfly and delta holes. Ribbed hook keeps merchandise from sliding. Fits ¼" pegboard holes and most slatwall. Available in white.	
	4" L	HK0143-4WH
	6" L	HK0143-6WH
	8" L	HK0143-8WH

	Wire and Corrugate Display Butterfly Hook	
	Holds packages with butterfly and delta holes. Fits ⅛" - ¼" corrugate and .148" - .177" diameter wire. Available in white.	
	2" L	HK0139-2WH
	3" L	HK0139-3WH
	4" L	HK0139-4WH
	5" L	HK0139-5WH
	6" L	HK0139-6WH
	7" L	HK0139-7WH
	8" L	HK0139-8WH

	Wire and Corrugate Display Hook	
	Holds packages with a variety of hole styles. Fits ⅛" - ¼" corrugate and .148" - .177" diameter wire. Available in white.	
	2" L	HK0138-2WH
	3" L	HK0138-3WH
	4" L	HK0138-4WH
	5" L	HK0138-5WH
	6" L	HK0138-6WH
	8" L	HK0138-8WH

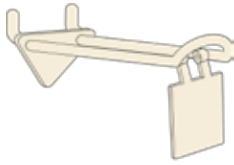
	Double Round Hook with Tab	
	Tab measures 1" x 1⅜". Available in white and black. Custom colours also available (minimum order required).	
	2" L	HK0232
	4" L	HK0234
	6" L	HK0236
	8" L	HK0238

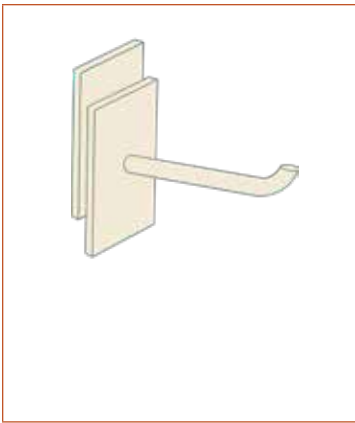

Display Hook	
Use with a variety of package hole styles. Fits 1/8" corrugate. Available in white.	
2" L	HK0142WHT
4" L	HK0144WHT
5" L	HK0145WHT
6" L	HK0146WHT
7" L	HK0147WHT
8" L	HK0148WHT

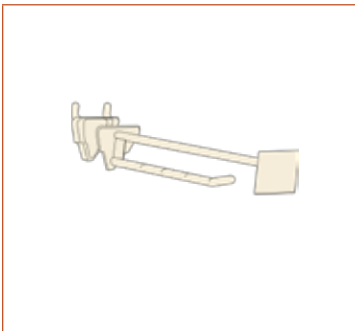

Two-Piece Scanner Hook	
Available in white and black. Custom colours also available (minimum order required).	
2" L	HK0322
4" L	HK0324
6" L	HK0326
8" L	HK0328

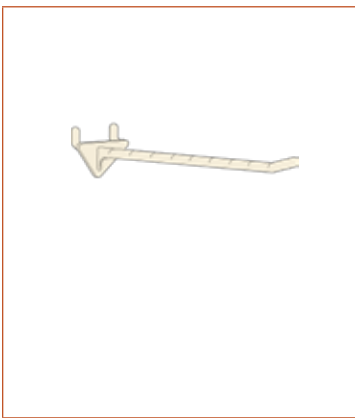

Ribbed Round Hook	
Available in white and black. Custom colours also available (minimum order required).	
1" L	HK0121
2" L	HK0122
3" L	HK0123
4" L	HK0124
6" L	HK0126
8" L	HK0128

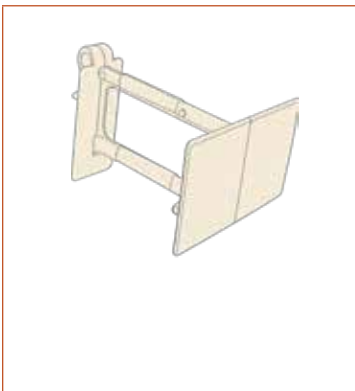

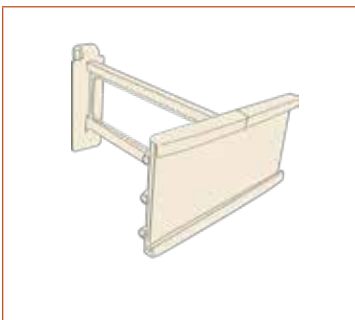

Wire and Corrugate Display Hook with Scan/Label Plate	
Holds packages with a variety of hole styles. Scan plate measures 1 3/8"H x 2 1/8"W. Fits 1/8" - 1/4" corrugate and .148"-.177" diameter wire.	
2" L	HK0140-2WH
3" L	HK0140-3WH
4" L	HK0140-4WH
6" L	HK0140-6WH
8" L	HK0140-8WH





Wire and Corrugate Display Hook with C-Channel	
Holds packages with a variety of hole styles. C-channel size measures 1 1/4"H x 3"W. Fits 1/8" - 1/4" corrugate and .148" - .177" diameter wire. Available in white.	
3" L	HK0141-3WH
4" L	HK0141-4WH
6" L	HK0141-6WH

	Scanner Hook	
	Available in white and black. Custom colours also available (minimum order required).	
	2" L	HK0312
	4" L	HK0314
	6" L	HK0316
	8" L	HK0318

NEW 	Tapered Display Hook With Scan Plate	
	Fits 1/8" (B-Flute) corrugated having "T" slots for insertion. Available in White and custom colours (minimum order required).	
	2" L	HK0182WH
	4" L	HK0184WH
	6" L	HK0186WH
	8" L	HK0188WH

NEW 	Tapered Display Hook With "C" Channel	
	Fits 1/8" (B-Flute) corrugated having "T" slots for insertion. Available in White and custom colours (minimum order required).	
	4" L	HK0194WH
	6" L	HK0196WH

NEW 	Corrugated Universal Display Hook With "C" Channel	
	Fits 1/8" (B-Flute) corrugated having 1" on centre X-cuts for insertion. Available in White and custom colours (minimum order required).	
	4" L	HK0154WH
	6" L	HK0156WH

NEW 	Corrugated Universal Display Hook With Scan Plate	
	Fits 1/8" (B-Flute) corrugated having 1" on centre X-cuts for insertion. Available in White and custom colours (minimum order required).	
	2" L	HK0162WH
	4" L	HK0164WH
	6" L	HK0166WH

NEW 	Pegboard/Slatwall Display Hooks With "C" Channel	
	Fits standard 1/4" diameter pegboard holes and all standard slatwall grooves. Available in White and custom colours (minimum order required).	
	4" L	HK0184WH
	6" L	HK0184WH

NEW



Corrugated Universal Display Hook With T-Scan Bar

Fits 1/8" (B-Flute) corrugated having 1" on centre X-cuts for insertion.
Available in White and custom colours (minimum order required)

2" L	HK0172WH
4" L	HK0174WH
6" L	HK0176WH

NEW

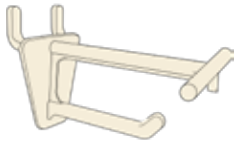

Pegboard/Slatwall Display Hooks With T-Scan Bar

Fits standard 1/4" diameter pegboard holes and all standard slatwall grooves.
Available in White and custom colours (minimum order required).

2" L	HK0912WH
4" L	HK0914WH
6" L	HK0916WH

NEW



All-Wire Pegboard Hook With Scan Hook

Simple all-wire hook design easy installation. Downturn-style bottom hook for added safety
Made of zinc plated steel material. Other sizes and finishes available (minimum order required)
Packaged 25 per bag

4" L x .186" Diameter (7 ga.)	HKW014
6" L x .186" Diameter (7 ga.)	HKW016
8" L x .186" Diameter (7 ga.)	HKW018
6" L x .212" Diameter (4 ga.)	HKW0162
8" L x .212" Diameter (4 ga.)	HKW0182
10" L x .212" Diameter (4 ga.)	HKW01102
12" L x .212" Diameter (4 ga.)	HKW01122

NEW



Single Prong All-Wire Pegboard Hook

Upturn-style end with ball tip for added safety. Made of zinc plated steel material. Other sizes and finishes available (minimum order required). Packaged 25 per bag.

4" L x .149" Diameter (9 ga.)	HKW0441
6" L x .149" Diameter (9 ga.)	HKW0461
8" L x .149" Diameter (9 ga.)	HKW0481
4" L x .186" Diameter (7 ga.)	HKW044
6" L x .186" Diameter (7 ga.)	HKW046
8" L x .186" Diameter (7 ga.)	HKW048
10" L x .186" Diameter (7 ga.)	HKW0410
4" L x .212" Diameter (4 ga.)	HKW0442
6" L x .212" Diameter (4 ga.)	HKW0462
8" L x .212" Diameter (4 ga.)	HKW0482
10" L x .212" Diameter (4 ga.)	HKW04102
12" L x .212" Diameter (4 ga.)	HKW04122

NEW



Shelf-Top Hook for Flag or Flush Merchandising

Securely hang merchandising strips from most perforated metal shelf holes. Two styles to choose from: "flag" which holds strips perpendicular (vertical) to the shelf front, and "flush" which holds strips parallel (horizontal) to the shelf front. Made of 0.135" diameter zinc plated steel wire.

3½"W	Flag	ACC201FLAG
4"W	Flush	ACC201FLUSH

NEW



All-Wire Pegboard Hook With T-Scan Bar

T-Scan bar in front accepts Label Holders that flip up and out of the way for product access. Simple all-wire hook design easy installation. Downturn-style bottom hook for added safety. Made of zinc plated steel material. Other sizes and finishes available (minimum order required). Packaged 25 per bag.

4" L x .186" Diameter (7 ga.)	HKW024
6" L x .186" Diameter (7 ga.)	HKW026
8" L x .186" Diameter (7 ga.)	HKW028
10" L x .186" Diameter (7 ga.)	HKW0210
8" L x .212" Diameter (4 ga.)	HKW0282
10" L x .212" Diameter (4 ga.)	HKW02102
12" L x .212" Diameter (4 ga.)	HKW02122

NEW



All-Wire Pegboard Hook With Scan Plate

Scan plate front is 1-3/8" high x 2-1/8" wide with radiused corners for safety. Downturn-style bottom hook for added safety. Made of zinc plated steel material. Other sizes and finishes available (minimum order required). Packaged 25 per bag.

4" L x .186" Diameter (7 ga.)	HKW034
6" L x .186" Diameter (7 ga.)	HKW036
8" L x .186" Diameter (7 ga.)	HKW038
4" L x .212" Diameter (7 ga.)	HKW0342
6" L x .212" Diameter (4 ga.)	HKW0362
8" L x .212" Diameter (4 ga.)	HKW0382
10" L x .212" Diameter (4 ga.)	HKW03102
12" L x .212" Diameter (4 ga.)	HKW03122

Inventory Control Units

NEW

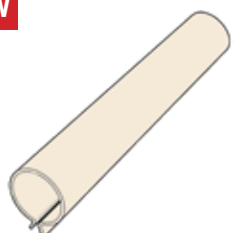

Inventory Control Tube

Flared leg opening works with most peg, slatwall and display hooks. Available in white. Custom lengths available (minimum order required).

2" L x ½" ID	ACC5042
3" L x ½" ID	ACC5043

NEW



Squeeze Style Inventory Control Unit

Squeeze wings to open clip for easy attachment to hooks.
 .375" thick
 Fits most standard metal and plastic display hooks
 Can be used as an inventory control unit or a product stop
 Made of flexible vinyl material

.162" to .207" Grip range

ACC505WH

.200" to .280" Grip range

ACC505BK

NEW



Butterfly Hook Product Stop

Flexible butterfly shape quickly attaches to butterfly display hooks
 Made of black PVC material

1¼" L x ¼" W

ACC5021

NEW

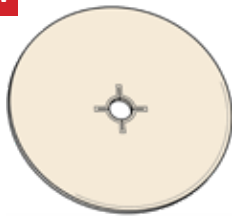

Display Hook Product Stop

Flexible design easily presses into place
 .040" thick
 Round shape with a center cross-cut hole
 Natural low-density polyethylene material

1" OD

ACC5031



Inventory Control Clip

Use to keep products towards the front of the hook. Moulded from soft plastic.

R23-135



Product Stop - Black

Use as an inventory control unit or product stopper. Three holes fit a variety of standard hooks. 1" diameter. Manufactured in black rubber.

Bag of 250

ACC500

NEW

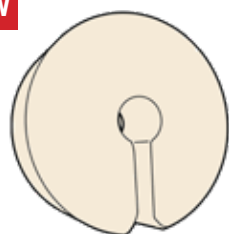

Round Inventory Control Unit





Slotted side opening
 .300" thick
 Can be used as an inventory control unit or a product stop
 Works with most peg and slatwall hooks
 Available in White, Black, Clear and custom colours (minimum order required)



¾" OD

ACC506WH

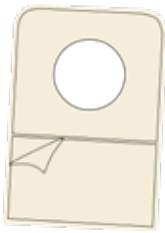

Hang Tabs

	<p>Fold-Up Hang Tab</p> <p>1½"H x 2½"W with delta hole.</p> <p>4500 Per Roll HK100</p>
	<p>Flexible Hang Tab</p> <p>1"W x 2"L with ½" diameter hole.</p> <p>10 Per Pad HK101</p>
	<p>Large Easy-Peel Hang Tab</p> <p>1½"H x 2"W</p> <p>HK061</p>
	<p>Basic Easy-Peel Hang Tab</p> <p>1¾"H x 1½"W</p> <p>HK062</p>
	<p>Easy-Peel Hang Tab</p> <p>¾"H x 1"W</p> <p>HK063</p>

	<p>Flexible Hang Tab - Wide</p> <p>1$\frac{7}{8}$"H x 2"W with delta hole.</p> <p>10 Per Pad HK103</p>
	<p>Hook Hang Tab</p> <p>1$\frac{3}{8}$"H x $\frac{7}{8}$"W</p> <p>HK102</p>
	<p>Hang Tab Sheet</p> <p>1$\frac{1}{2}$"H x $\frac{7}{8}$"W with $\frac{1}{2}$" diameter hole.</p> <p>36 Per Sheet HK064</p>
	<p>Hang Tab Sheet - Wide</p> <p>1$\frac{1}{8}$"H x 1$\frac{1}{2}$"W</p> <p>20 Per Sheet HK066</p>
	<p>Hang Tab - Individual</p> <p>1$\frac{3}{4}$"H x 1$\frac{5}{8}$"W</p> <p>Sold Individually HK068</p>
	<p>Hang Tab - Cylinder</p> <p>Supports up to 5lbs.</p> <p>$\frac{3}{8}$"W x 6"L HS0010</p>

	<p>Handle Strap - Large</p> <p>Supports up to 30 lbs.</p> <p>1 3/8"W x 23"L HS0020</p>
	<p>Handle Strap - Small</p> <p>Support up to 15 lbs.</p> <p>1"W x 17"L HS0015</p>
	<p>Handle - Easy Carry</p> <p>Supports up to 5lbs.</p> <p>3 1/8"H x 5 1/2"W HS0005</p>

Ceiling Hangers

	<p>Rotating Ceiling Hook</p> <p>Locks onto 1" drop ceiling grid and is designed for easy attachment and removal. Rotates into place. Manufactured in polycarbonate.</p> <p>Clear ACC170</p>
	<p>Ceiling Grip Clip</p> <p>Repositionable clip that snaps onto a standard 1" drop ceiling grid. The 1/8" diameter hole is for barbed hanging cords. Manufactured in butyrate.</p> <p>Clear ACC175</p>



Ceiling Twist Clip

Snap hinge locks securely to standard 1" drop ceiling grid and twists off easy removal. Extends 1½" from ceiling. Manufactured in polypropylene.

White ACC176



Ceiling Loop

Permanent adhesive base sticks to standard drop ceiling grid. The ¼" loop opening is great for barbed cords, double C-hooks and jet wire. Manufactured in styrene.

White ACC180

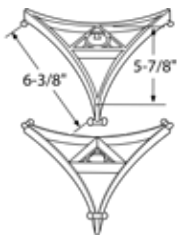

Mini Triarama Mobile Kit

Three-sided mobile gives you maximum exposure from ceiling, shelf or floor. Plastic formers hold 3 panels from 10" to 24" wide. Kit includes a top and bottom former, twist-on mini hook and cord.

ACC190

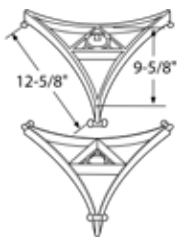

Triarama Mobile Kit

Three-sided mobile gives you maximum exposure from ceiling, shelf or floor. Plastic formers hold 3 panels from 15" to 40" wide. Kit includes a top and bottom former, twist-on mini hook and cord.

ACC191

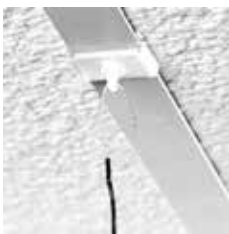
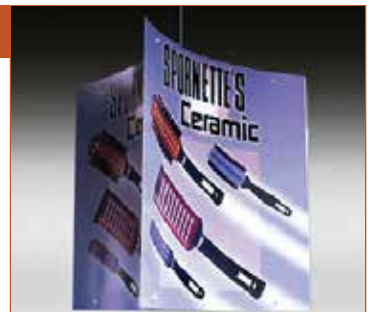

Mobile Spring

Hangs displays at exactly the height you want. Made from steel wire.

6" (Stretches to 4') HK22206

8" (Stretches to 5') HK22208

12" (Stretches to 8') HK22212



Mini Twist-On Clip

All-in-one solution for hanging light signs and banners from a 1" drop-ceiling grid. Comes with white cotton or monofilament cord.

White ACC240



Twist-On Clip

For use on standard 1" drop-ceiling grid. Simply align connector to drop-ceiling grid and twist. Works with s-hooks, chains, jet wire and cable connectors. Manufactured in medium impact polystyrene.

ACC241



Metal Grid Clip

Squeezes onto standard 1" drop-ceiling grid. Excellent connector to hang lightweight mobiles, signs, banners and decorations. Made from galvanized spring steel.

ACC250

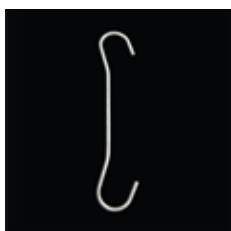

Double C-Hook

Nickel plated wire.

6"L	DCH06
12"L	DCH12
24"L	DCH24
36" L	DCH36



Elastic Cord with Barbs

Elastic cords that stretch to approximately twice their length. Black polyester with silver barbs.

Cord lengths range from 1" - 18"	ACC801 - ACC818
----------------------------------	-----------------

Suction Cups

Approximate holding weight by size:

Small 1 1/8" diameter	1lbs
Medium 1 3/4" diameter	3lbs
Large 2 1/2" diameter	7lbs



Suction Cup with Mushroom Head

Simplified design supports a wide range of self-hanging products.

1 1/4" Diameter	Small	ACC100
1 3/4" Diameter	Medium	ACC101
2 1/2" Diameter	Large	ACC102



Suction Cup with Metal U-Hook

Deep hook design is ideal for window-mounted signs, ornaments or decorations.

1¼" Diameter	Small	ACC120
1¾" Diameter	Medium	ACC121
2½" Diameter	Large	ACC122



Suction Cup with #8-32 Stud and Nut

The preferred hanger for screw-mountable signs, thermometers, etc. Brass knurled nut.

1¼" Diameter	Small	ACC130
1⅞" Diameter	Medium	ACC131
2½" Diameter	Large	ACC132



Suction Cup with Check Hook

Suction cup with rust-proof hanging hook

1¾" Diameter	ACC140
--------------	--------



Suction Cup with Plated Metal Clamp

Holds signs and posters on glass, refrigerators and other slick surfaces.

1⅞" Diameter	ACC150
1⅞" Diameter	ACC151

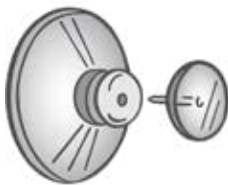

Suction Cup with Thumbtack

Holds signs and posters on glass, refrigerators and other slick surfaces.

1¾" Diameter	ACC700
--------------	--------



Grippa™ Mushroom Head Suction Cup

Used to hang Multi-Purpose Adjustable Bins to glass or smooth or flat surfaces.

ACC950

Fasteners



Universal Push Pin

½" diameter head. Fits ¼" Diameter Holes. Made of natural nylon.

Natural	UPP001
Black	UPP001BK



Christmas Tree Push Pin

¾" diameter head. Fits ¼" diameter holes. Made from natural nylon.

Natural	PPN001
Black	PPN001BK



Belly Button Push Pin

To securely attach dividers to shelves. For ¼" diameter holes 100 per bag, natural nylon.

Natural	PPN002
Black	PPN002BK

NEW



Quick Grip Washer Fastener

Two piece construction (screw & retaining washer combination) provides a secure, non-removable hold. Features fast attaching "slide-on" retaining nut for quick assembly of signs and displays. Fits 3/16" hole size. Round screw head and retaining washer fastener are 9/16" O.D. Made of clear polycarbonate material.

⅝" L	ACC044
⅞" L	ACC045

NEW

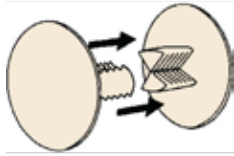

Ratchet Rivet Fastener

Press two pieces together. Serrated teeth adjust to a variety of locking depths and join panels together in a secure and permanent manner. Complete assembly requires two pieces Fits into 9/32" diameter hole size.

.235" - .297" Capacity	Natural colour	ACC124
.346" - .500" Capacity	Black	ACC125
.500" - .812" Capacity	Black	ACC126

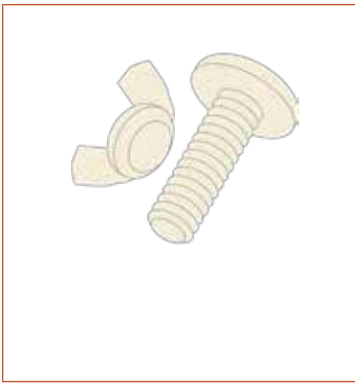

Screw and Wing Nut Set

To securely attach dividers to shelves. 100 per bag.

#10 - 24 x 3/4"	PPN003
-----------------	--------

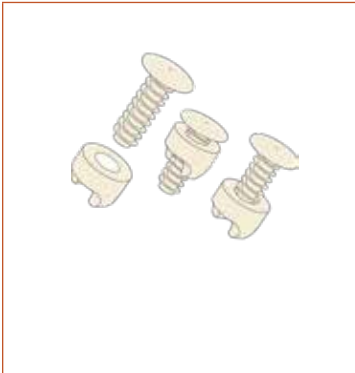

Viking Screws

1/2" head diameter. Fits 1/4" diameter hole. Made of clear styrene.

7/8" L	ACC040
1 1/2" L	ACC042

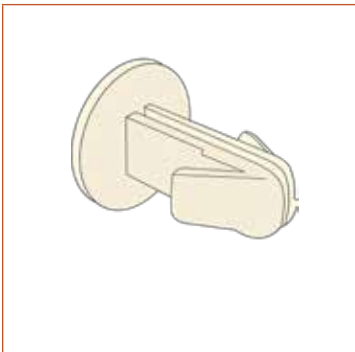

Arrowhead Thumb Snap

.2" Grip with 1/2" diameter head. Available in black and clear polypropylene. Fits 1/4" diameter holes.

Clear	ACC111CL
Black	ACC111BK

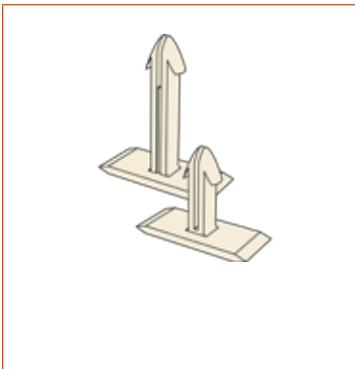

Arrow Fastener

Securely holds pads of coupons or single signs in a centred position. Stem 1/2"L. Manufactured in natural polypropylene.

Arrow Fastener	w/ Adhesive	ACC110A
Arrow Fastener	w/o Adhesive	ACC110NA

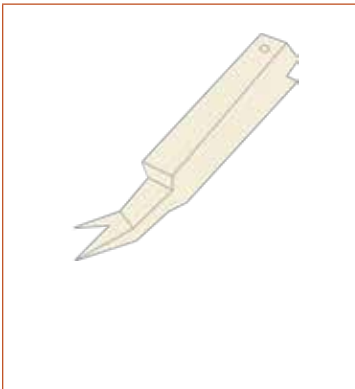

Universal Push Pin Remover

Ideal for removing fasteners from shelves.

	PPR001
--	--------

Floor Standing Merchandiser

How It Works: Floor Standing Merchandiser

Capitalize on impulse sales with MIL's 360° Floor Standing Merchandiser. Fully customizable to suit your needs, our Floor Standing Merchandiser is comprised of modular pieces that allow you to setup your display the way you want. Add up to eight levels of our Multi-Purpose Bins, suspended from a Three-Way Wire Carousel or Four-Way Wire Carousel. Top off your display with eye catching signage using our Sign Clip Adaptor and/or a Clear Bowl for showcasing a product of the week.

1 Choose Your Pole and Base



- a** DP001: Display Pole
- b** DB0004: Cross Base
- c** DB0003: Octagonal Base
- d** DB0002: Trumpet Base

2 Select the Accessories

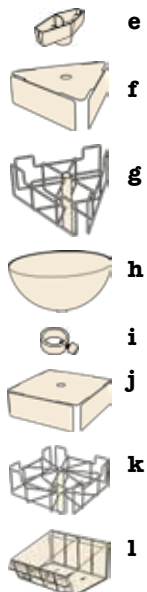

- e** SCH415: Sign Clip Adaptor
- f** WB3W: Three-Way Baffle
- g** WC3W: Three-Way Carousel
- h** MB0005: Clear Bowl with Stem
- i** SHC414: Plastic Support Clamp
- j** WB4W: Four-Way Baffle
- k** WC4W: Four-Way Wire Carousel
- l** PEGBIN010: Multi-Purpose Bins

Possible Configurations

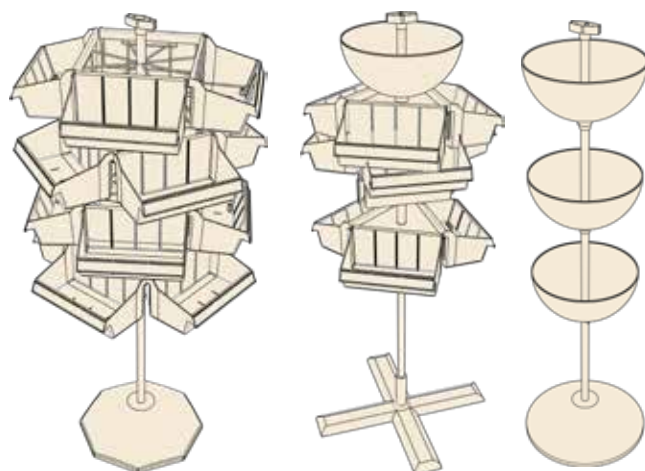

Display Pole - Corrugate



Two-piece, 6' long pole. Comes in three diameters. Inner core holds pole pieces securely together. Available in White (litho paper finish). Additional sizes and colours also available. Pole requires wire feet to stand.

1" OD - 1/4" ID	SHA240A
1 1/2" OD - 1 1/4" ID	SHA240B
1 3/4" OD - 1 1/2" ID	SHA240C

Display Pole - Metal





Custom colours available (minimum order required).

61" H	DP0061
63" H x 1" OD	DP0063
69" H x 1 1/4" OD	DP0069125
71" H x 1 1/4" OD	DP0071125

	Wire Feet for Display Pole	
	Two-piece set of overlapping wires slip into Display Pole base to create a sturdy base. Available in three sizes for different diameter poles. 24" span. Made from wire.	
	24" OD - 7/8" ID	SHB160A
	24" OD - 1 1/4" ID	SHB160B
24" OD - 1 1/2" ID	SHB160C	

NEW 	Snap-Out Pole Base	
	Supports 1" Pole with 5 1/2" reduced bottom. Requires a special swedge for 1" pole.	
	7 1/4"H x 24"W	DPB01

NEW 	Knock Down Pole Base	
	Supports 1" - 1 1/4" pole.	
	4"H x 26"W	KDPB01

NEW 	Fiber Pole Foot	
	Fits pole sizes 1 3/4" and 2" OD	
	26"W	FDPB01

	Trumpet Base	
	Trumpet Base	
		DB0002

	Octagonal Base	
	Octagonal Base	
		DB0003

	<p>Cross Base</p> <p>Cross Base DB0004</p>
	<p>Display Pole Sign Holder</p> <p>Holds sign securely at the top of display poles (SHA240A, SHA240B, SHA240C). Fits 1" OD or 1½" ID poles. Holds 18pt. - 60pt. material.</p> <p>Fits 1" ID or 1½" OD SHC410 Fits ⅞" ID SHC411</p>
	<p>Sign Holder with Gripper for Display Poles</p> <p>Add signage to display poles (SHA240A, SHA240B, SHA240C). Fits poles with 1" OD and ¼" ID. Holds material up to ¼" thick. White styrene base with clear PVC sign holder.</p> <p>3"L SHC405</p>
	<p>Sign Clip Adaptor</p> <p>Securely display signage on top of a 1" diameter Display Pole (SHA240A). Holds material from 60pt. to ¼" thick.</p> <p>3½" Long SHC415</p>
	<p>Sign Holder Pole Gripper</p> <p>Clips onto 1"OD pole or tube. Holds material up to ¼" thick. Manufactured in clear PVC.</p> <p>3" SHC400</p>
	<p>Clear Bowl with Stem</p> <p>Capitalize on impulse sales by adding the Clear Bowl to the 1" diameter Display Pole to merchandise your products. Fasten in place with a Plastic Support Clamp.</p> <p>6¾"H x 14" Diameter MBC005</p>



Plastic Support Clamp	
Use with the 1" diameter Display Pole SHA240A to support merchandising systems that need fastening.	
1" Inside Diameter	SHC414
1¼" Inside Diameter	SHC414-LG

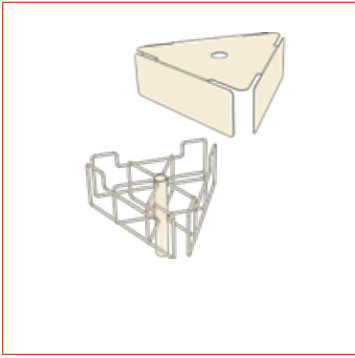

Three-Way Wire Carousel	
Custom colours available (minimum order required).	
Three-Way Wire Carousel	WC3W
Three-Way Baffle	WB3W

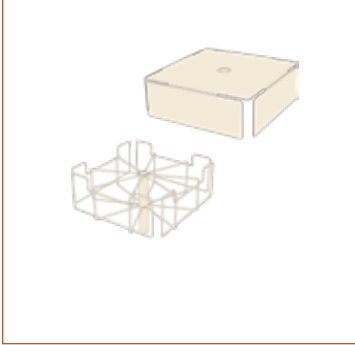

Four-Way Wire Carousel	
Custom colours available (minimum order required).	
Four-Way Wire Carousel	WC4W
Four-Way Baffle	WB4W



NEW SIZES!		Multi-Purpose Clear Bins	
Bins are stocked in clear. Custom colours available (minimum order required).			
5⅞"H x 11⅞"W x 7½"D	Small Bin	PEGBIN010	
5⅞"H x 11⅞"W x 10¼"D	Medium Bin	PEGBIN015	
5⅞"H x 11⅞"W x 12⅝"D	Large Bin	PEGBIN020	
5½"H x 11½"W x 14"D	Extra Large Bin	PEGBIN025	
5½"H x 11½"W x 16"D	Jumbo Bin	PEGBIN030	

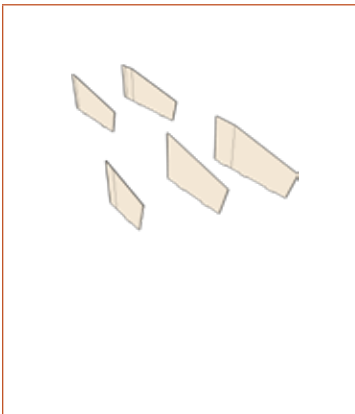

Multi-Purpose Clear Bin Dividers	
Mounts to Multi-Functional Tray to create up three compartments. Dividers and Bins are stocked in clear. Custom colours available (minimum order required).	
Small Divider	PDIV010
Medium Divider	PDIV015
Large Divider	PDIV020
Extra Large Divider	PDIV025
Jumbo Divider	PDIV030

NEW



Clear Plastic Tub - 6" Diameter

Use on counters and in checkout areas to hold and display impulse purchase like candies and party supplies. Made of clear durable material.

6 1/8"H x 6" Diameter with 3/8" lip

TU16DIS

NEW



Slatwall Hanging Bowl

This kit includes a clear plastic bowl on an 8 3/4" metal extension arm. Use on a pegboard or slatwall display.

10"H x 5"W x 8 3/4"D

PEGBOWL010

12"H x 6"W x 8 3/4"D

PEGBOWL020

14"H x 7"W x 8 3/4"D

PEGBOWL030



Revolving Clip Strip Display

A revolving display made of six Clip Strips, with 108 clips. Clip Strips are spaced 4" apart. Available in black and red

63"H x 9"D Base

RCSD001

NEW



Four-Tiered 14" Bowl Floor Display

These 14" bowls are supported on a flat base and are made of durable clear polycarbonate. They can sustain high impacts while maintaining their crystal finish. T-Strip Sign Holder included with the display.

60"H x 14"D

4BOWLDISPLAY

NEW



Four-Tiered 14" Tub Floor Display

These 14" bowls are supported on a flat base and are made of durable clear polycarbonate. They can sustain high impacts while maintaining their crystal finish. T-Strip Sign Holder included with the display.

60"H x 14"D

4TUBDISPLAY



Utility Cube

Injection moulded ABS cubes with 6 HDPE drawers and dividers.

12"H x 12"W x 16"D

850.421





Merchandising Solutions

We've got great ideas: Solutions for almost any challenge. If you don't see it here, we'll design a solution just for you! Maximize your sales and achieve your display objectives.

Multi-Purpose Bins & Accessories

Our Multi-Purpose Bins are designed for showcasing bulk products. Place up to 3 dividers to maximize your sales and profitability. Hangs off pegboard, wire or slatwall using clear U-hooks. Our Multi-Purpose Bins offer a graphic track for signage and are available in 5 sizes.



Multi-Purpose Clear Bins

NEW SIZES!

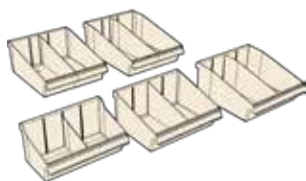

Multi-Purpose Clear Bins

Bins are stocked in clear. Custom colours available (minimum order required).

5 $\frac{7}{8}$ "H x 11 $\frac{3}{8}$ "W x 7 $\frac{1}{2}$ "D	Small Bin	PEGBIN010
5 $\frac{7}{8}$ "H x 11 $\frac{3}{8}$ "W x 10 $\frac{1}{4}$ "D	Medium Bin	PEGBIN015
5 $\frac{7}{8}$ "H x 11 $\frac{3}{8}$ "W x 12 $\frac{5}{8}$ "D	Large Bin	PEGBIN020
5 $\frac{1}{2}$ "H x 11 $\frac{1}{2}$ "W x 14"D	Extra Large Bin	PEGBIN025
5 $\frac{1}{2}$ "H x 11 $\frac{1}{2}$ "W x 16"D	Jumbo Bin	PEGBIN030



Multi-Purpose Clear Bin Dividers

Mounts to Multi-Functional Tray to create up three compartments. Dividers are stocked in clear. Custom colours available (minimum order required).

Small Divider	PDIV010
Medium Divider	PDIV015
Large Divider	PDIV020
Extra Large Divider	PDIV025
Jumbo Divider	PDIV030



Multi-Purpose Tray

Pegboard/Slatwall brackets and divider included. Trays are stocked in clear. Custom colours available (minimum order required)

3H" x 16"W x 9"D	PEGTRAY010
------------------	------------

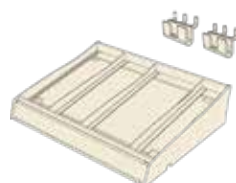

Cosmetics Tray

Clear tray with flip-front label holder. Rests on a counter or hooks onto a wall. Sides lock together. Moulded in crystal styrene. Includes two clear Pegboard/Slatwall U-hooks.

11 $\frac{7}{8}$ "W x 8"D	Clear	COSMTRAY-01
11 $\frac{7}{8}$ "W x 8"D	Black	COSMTRAY-02BK

How It Works: Multi-Purpose Bins



Attaches to Wire Racks



Attaches to Pegboard



Colour Options



Attaches to Slatwall



Attaches to Glass



Cosmetic Tray Divider

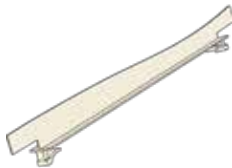

Dividers for use with our Cosmetics trays. Slides left and right to adjust to various product widths. Moulded in clear styrene.

1 1/8" H x 8" D	Clear	COSMDIV208
1 1/8" H x 8" D	Black	COSMDIV208BK

Adjustable Depth Cosmetic Tray Bracket

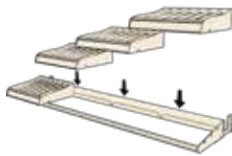

Holds four Cosmetic Trays and mounts directly to a gondola. Bracket depth adjusts from 8" to 16" in preset 3/8" increments.

3" H x 48" W x 8"-16" D	COSMTRAYBRKT
-------------------------	--------------

Pegboard / Slatwall U-Hook - Clear

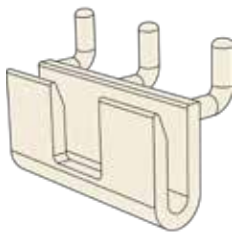

Used to hang Multi-Purpose Adjustable Bins to pegboard or slatwall.



2 1/4" W	PEG004
----------	--------

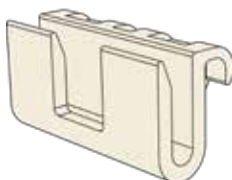



Wire / Flat Fence U-Hook - Clear

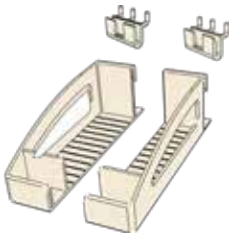
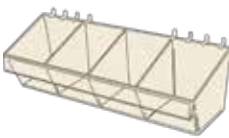

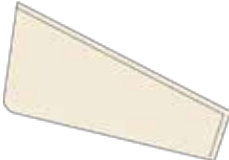
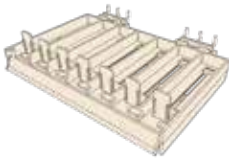
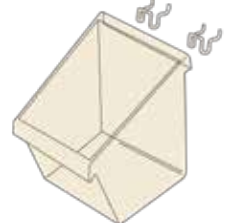
Used to hang Multi-Purpose Adjustable Bins to wire or flat fence.

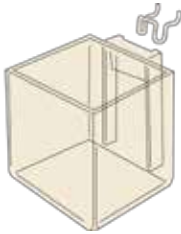
2 1/4" W	PEG006
----------	--------

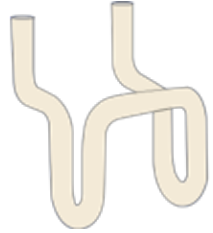
	<p>Slatwall/Pegboard Frame Holder</p> <p>Linens, books, picture frames and more; these shelves hold a wide variety of products.</p> <p>2¾"W x 10"L SHEFR001</p>
	<p>Multi-Functional Divider Bin</p> <p>Showcase and organize multiple products in one bin using up to three dividers. Bin mounts to slatwall or pegboard. Made of clear acrylic.</p> <p>13"W x 4"D PEGBIN001</p>
	<p>Multi-Functional Divider Tray</p> <p>Showcase and organize multiple products in one bin using up to three dividers. Bin mounts to slatwall or pegboard. Made of clear acrylic.</p> <p>13"W x 7"D PEGBIN002</p>
	<p>Dividers for Adjustable Bin and Tray</p> <p>Add up to three dividers per bin or tray to create up to four compartments. Made of clear acrylic.</p> <p>4" PEGDIV001 7" PEGDIV002</p>
<p>NEW</p> 	<p>Seven-Lane Pusher Nail Tray</p> <p>Clear tray with flip-front label holder. Made of crystal styrene.</p> <p>2¼" H x 12" W x 8" D COSMTRAY-03CLR</p>
	<p>Bucket Display</p> <p>Clear acrylic bucket can be used on pegboard, slatwall or any flat surface. Includes two metal U-hooks.</p> <p>7"H x 4½"W x 4"D PEGBIN003 9"H x 7½"W x 9"D PEGBIN004</p>

	<p>Cube Bin</p> <p>Can be mounted on pegboard, slatwall or used as a counter display. Includes one metal U-hook. Made of clear acrylic.</p> <p>4"H x 4"W x 4"D PEGBIN005</p>						
	<p>Cup Display</p> <p>Mounts to pegboard or slatwall with the included hook. Can also be used as a counter display. Made of clear acrylic.</p> <p>3¼"H x 4"D PEGCUP001</p>						
	<p>U-Hook - Clear Plastic</p> <p>Hang displays, bins and trays from slatwall or pegboard. Manufactured in high impact plastic.</p> <p>¾"H x 1¼"W x ½"D PEG001</p>						
	<p>U-Hook - Metal</p> <p>Hangs displays, bins and trays from slatwall or pegboard. 148" hook diameter. Galvanized finish.</p> <p>¾"H x 1⅞"W x ½"D PEG002</p>						
	<p>Slatwall/Pegboard Powerwing Clip</p> <p>Holds corrugated displays flush to standard pegboard and slatwall. Prongs fit pegboard with 1" holes on centre.</p> <p style="text-align: right;">PW3550</p>						
	<p>Slatwall Powerwing Clip</p> <p>Upper lip fits corrugated display to most standard slatwall.</p> <table border="0" style="width: 100%;"> <tr> <td>2"W</td> <td style="text-align: right;">PW3500</td> </tr> <tr> <td>1"W</td> <td style="text-align: right;">PW3510</td> </tr> <tr> <td>1½"W</td> <td style="text-align: right;">PW3520</td> </tr> </table>	2"W	PW3500	1"W	PW3510	1½"W	PW3520
2"W	PW3500						
1"W	PW3510						
1½"W	PW3520						

	<p>Corrugate Powerwing Clip</p> <p>Attaches corrugate displays to Powerwing or Power Bar. Designed for easy installation.</p> <p>2¼”H x 1¼”L PW3570</p>
	<p>Power Bar</p> <p>Attaches corrugate displays to most shelves with adjustable arms.</p> <p>15½”L Adjustable PW3590</p>
	<p>Pegboard / Slatwall Adapter</p> <p>Attaches lightweight displays to pegboard or slatwall. Fits standard ¼” pegboard holes. Permanent adhesive included.</p> <p>1¼”H x 3½”L PW3575</p>
	<p>Warehouse Powerwing Clip</p> <p>Securely attaches displays to most standard warehouse uprights.</p> <p>2⅞”H x 1½”L PW3580</p>

Cooler Merchandising Racks

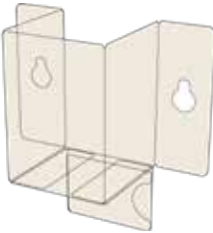
	<p>Beverage Holder</p> <p>Fits 2¾” diameter can. Includes two standard suction cups. Product Area: 2½” x 3½” x 2¾”. Label Area: 2½” x 3”. Made from clear Co-Poly.</p> <p style="text-align: right;">BEV005</p>
---	---

	<p>Cooler Merchandiser Rack - 20 oz.</p> <p>Fits five 20oz. bottles or five 24oz. cans. Includes six standard suction cups. Diameter: 2¾". Label Area: 2½"H x 14½"W. Made from break-resistant PET plastic.</p> <p style="text-align: right;">BEV002</p>
	<p>Cooler Merchandiser Rack - 16 oz.</p> <p>Fits five 16oz. bottles. Includes six standard suction cups. Diameter: 2⅝". Label Area: 2½"H x 13¼"W. Made from break-resistant PET plastic.</p> <p style="text-align: right;">BEV001</p>
	<p>Merchandiser Rack - Large</p> <p>All purpose display made from crack-resistant PET plastic. Includes six power suction cups. Product Area: 3¾"H x 18½"W. Label Area: 2"H x 18"W.</p> <p style="text-align: right;">BEV004</p>
	<p>Merchandiser Rack - Small</p> <p>All purpose rack made from crack-resistant PET plastic. Includes four standard suction cups and can accommodate up to six suction cups to support heavier products. Product Area: 3¾"H x 16½"W Label Area: 1"H x 15"W.</p> <p style="text-align: right;">BEV003</p>
	<p>Shelf Extender</p> <p>Fits any standard sized store shelf. Made from crack-resistant PET plastic. Product Area: 15" x 4¼" x 3". Label Area: 14½" x 1". Bar Code Area: 2¼" x 1".</p> <p style="text-align: right;">SHEEXT001</p>

Produce Bins



How It Works: Produce Bin Merchandisers

Produce Bin Merchandisers are merchandising bins that fold for convenient shipping and storage. They can accommodate large and heavy weight products while letting you use a very small amount of perishable inventory. The Top Tray and Bottom Base are vacuum formed in black ABS plastic. Cardboard walls can be silkscreened with graphics on all sides or on the front only with Kraft on remaining sides.



BINO01
Flat Top Tray

CORSMA
Cardboard Body

BINHBO01
Bin Base

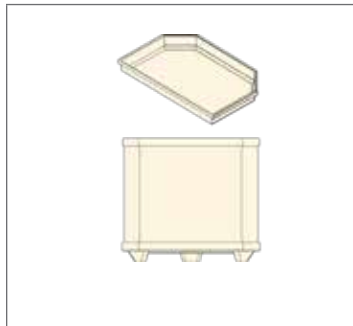
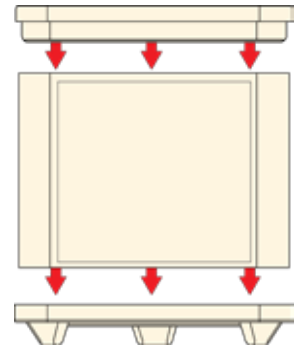

Small Produce Bin

Small Produce Bins are available in kraft colour. Top tray and bottom base are available in black. Base, Body and Flat Top Tray included in produce bin set.

Body Size: 36"H x 24"W x 36"D	Small Produce Bin Set	BINPRODUCEH
Tray Size: 3"H x 24"W x 36"D	Small Produce Bin Flat Top Tray	BINH001
Small Body		CORSMA
Small Produce Bin Base		BINHBO01

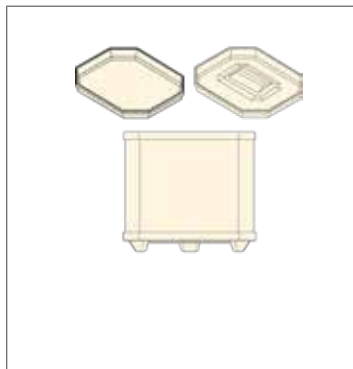

Large Produce Bin

Large Produce Bins are available in kraft colour. Top tray and bottom base are available in black. Base, Body and Flat Top Tray included in produce bin set. Specify type of tray when placing order.

Body Size: 35"H x 40"W x 47"D)	Large Produce Bin Set	BINPRODUCEF
Tray Size: 4"H x 40"W x 47"D)	Flat Surface Tray	BINF001
4"H x 40"W x 47"D	Tray with Middle Riser	BINR001
Large Body		CORLAR
Large Produce Bin Base		BINBO01

Inline Merchandising



How It Works: Inline Merchandiser

1 Start with two Satin Aluminum Posts and one Hinged Framed Slatwall

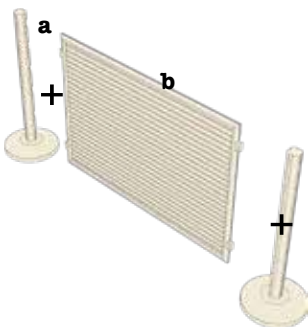

- a** CPOST001 Satin Post
- b** SLAPAN001 Hinged Framed Slatwall

2 Add optional signage and a merchandising bowl

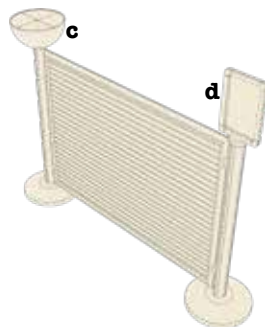

- c** MB001 Merchandising Bowl
- d** SHOVSMO711 Aluminum Sign Holder with Swivel Mount

3 Customise the display with additional accessories to meet your merchandising needs

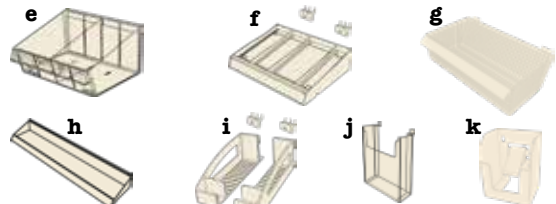

- e** PEGBIN010 Multi-Purpose Bin
- f** COSMTRAY-01 Multi-Functional Tray
- g** BASMET001 Metal Basket
- h** TRAYMET001 Metal Tray
- i** SHEFR001 Slatwall Frame Holder
- j** BHO320 Magazine Pocket Holder
- k** DVDB100 DVD Pusher Box



Slatwall with Metal Basket



Slatwall with Metal Tray



Framed and Hinged Aluminum Slatwall - Satin Finish

Use with two of our Aluminum Slatwall Posts to build a portable, double-sided, merchandising display.

35"H x 49"W

SLAPAN001



Aluminum Post with Grey Base - Satin Finish

A versatile and attractive solution for floor standing Point-of-Purchase merchandising. These posts feature a dovetailed attachment system, letting you to build a display with our modular display components. All posts feature rubberized non-slip bases that also protect floors from scratches.

40½"H x 14" Diameter Base

Centre Post

CPOST001

40½"H x 14" Diameter Base

End Post

EPOST001



Merchandising Bowl

Add a Merchandising Bowl to the top of our Aluminum Post to showcase small products. A great way to increase impulse sales!

6¼"H x 13¾" Diameter

MB0001

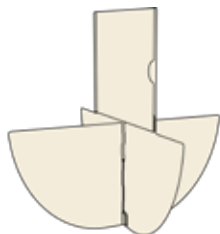

Bowl Divider with Sign Holder

Add eye-catching signage and dividers to our post-top merchandising bowl.

5½"H x 7½"W

SHODIV005

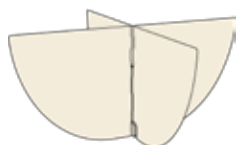

Bowl Divider

Use with our Merchandising Bowl to divide it into four sections.

SHODIV001



Satin Aluminum Sign Holder with Swivel Mount

Top off your satin-finish Aluminum Post with a matching sign frame. Frames are mounted to a swivel bracket allowing it to face any direction.

6½" x 10½"(Graphic Area) SHOVSM0711

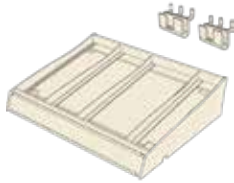

Multi-Functional Tray

Clear tray with flip-front label holder. Rests on a counter or hooks onto a wall. Locks together on sides. Moulded in crystal styrene. Includes two clear Pegboard/Slatwall U-hooks.

11⅞"W x 8"D COSMTRAY-01
 11⅞"W x 8"D COSMTRAY-02BK

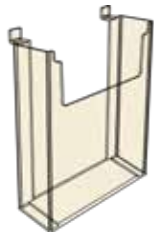

Magazine Pocket Holder

Pocket mounts to slatwall and holds standard sized 8½" x 11" magazines. Injection moulded.

11"H x 8½"W BHO320



DVD/Video Game Pusher Box

Front loading pusher box holds up to six DVDs or Video Games and keeps them upfront and forward facing. Mounting options include suction cup, shelf, pegboard and slatwall.

7¾"H x 5⅞"W DVDB100

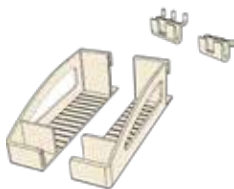



Slatwall/Pegboard/Wire Shelf Frame Holder

Linens, books, picture frames and more; these shelves hold a variety of merchandise. Position the left and right sides to fit your product. Add an optional Insert Shelf for larger products and volume. Inside shelf depth is 9½". Set includes left and right sides along with 2 mounting bracket for either Slatwall/Pegboard or Wire shelves. Specify type of mounting bracket when placing order. Hardware sold separately.

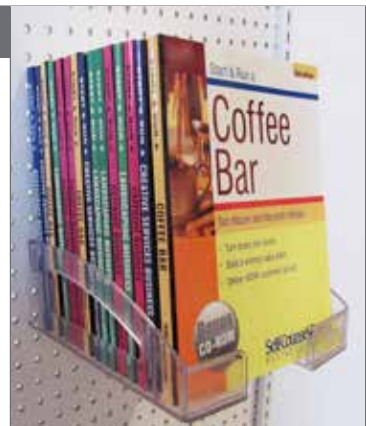

Slatwall Set SHEFR001





	<p>Metal Tray</p> <p>Heavy duty metal tray for use with our queuing system.</p>
	<p>48"W x 8"D TRAYMET001</p>



	<p>Metal Basket</p> <p>Heavy duty metal basket for use with our queuing system.</p>
	<p>6"H x 24"W x 11"D BASMET001</p>

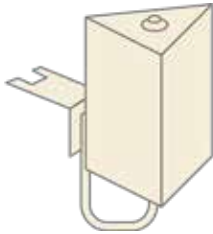

More Merchandising Ideas

	<p>Snap Banner Track</p> <p>Hanging signage is a snap! Just snap the clear track right onto the edge of your sign. Now you're ready to slide in eyelets, and hang the sign from the ceiling, or affix the track directly to a wall with double-sided tape. Available in black or clear.</p>	
	<p>Snap Banner Track (Standard Lengths up to 48") SHE2189</p> <p>Hanging Eyelet SHE2189EYE</p>	

	<p>Mercury Banner Hanger</p> <p>Snaps and hold banners securely.</p>
	<p>48"L (clear) SHE2180CLEAR48</p>

	<p>Three-Face Shelf Spinner</p> <p>Shelf Spinner with three panels for information. Easily mounts to a standard perforated shelf. Holds three cards 5¼"H x 2¾"W.</p>	
	<p style="text-align: right;">SHESPN</p>	

	<p>Checkout Mat</p> <p>A simple solution for checkout display promotions, photos, menus and more. Lift the clear panel to change your message in seconds. Durable construction with a non-slip underside. Viewable window 9$\frac{1}{8}$"H x 13$\frac{3}{4}$"W.</p> <p style="text-align: right;">CHKMAT</p>	
---	---	--

	<p>Deskwindo™</p> <p>Transform any desktop, countertop or checkout into an advertising opportunity. Display your fliers, sell sheets and product photos in this sleek, durable, low profile advertising tool. Available in black</p> <table border="1" data-bbox="462 609 1153 693"> <tr> <td>8$\frac{1}{2}$" x 11" Window</td> <td>WIN8511BK</td> </tr> <tr> <td>16$\frac{5}{8}$" x 11$\frac{3}{4}$" Window</td> <td>WIN1611BK</td> </tr> </table>	8 $\frac{1}{2}$ " x 11" Window	WIN8511BK	16 $\frac{5}{8}$ " x 11 $\frac{3}{4}$ " Window	WIN1611BK	
8 $\frac{1}{2}$ " x 11" Window	WIN8511BK					
16 $\frac{5}{8}$ " x 11 $\frac{3}{4}$ " Window	WIN1611BK					

<p>NEW</p> 	<p>Wire Dump Bin</p> <p>Bottom of wire bin can be set to three different heights to adjust its holding capacity. Available in black and white. Custom colours also available (minimum order required).</p> <table border="1" data-bbox="462 934 1510 987"> <tr> <td>30"H x 17"W x 18"D</td> <td>WDB001</td> </tr> </table>	30"H x 17"W x 18"D	WDB001
30"H x 17"W x 18"D	WDB001		

Standard Corrugated Displays

Quick and easy to assembly, most dump bins can also be flipped over to use two different depths. Custom printing available.

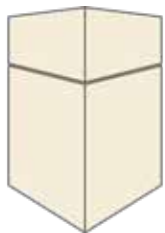
	<p>Rectangular Bin</p> <table border="1" data-bbox="462 1333 1510 1386"> <tr> <td>30"H x 14"W x 18"D</td> <td>SDB001</td> </tr> </table>	30"H x 14"W x 18"D	SDB001
30"H x 14"W x 18"D	SDB001		

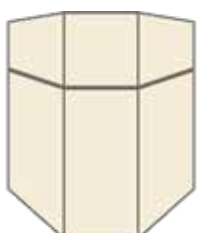
	<p>Hexagonal Dump Bin</p> <table border="1" data-bbox="462 1711 1510 1764"> <tr> <td>30"H x 9"W x 9"D</td> <td>SDB003</td> </tr> </table>	30"H x 9"W x 9"D	SDB003
30"H x 9"W x 9"D	SDB003		

	<p>Square Window Bin</p>
	<p>28"H x 14"W x 14"D SDB006</p>

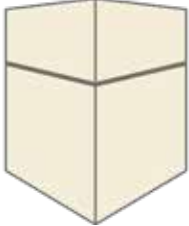
	<p>Square Bin</p>
	<p>30"H x 13"W x 13"D SDB002</p>

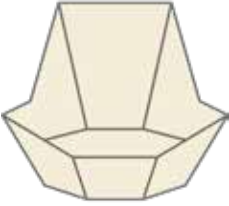
	<p>Countertop Display Bin</p>
	<p>10"H x 11"W x 6"D SDB004</p>

	<p>Ballot Box</p>
	<p>8½"H x 10"W x 8"D SDB005</p>



Countertop Display Bin & mounting hooks



Square Bin



Countertop Display Bin

Skid Fender



How It Works: Skid Fenders

Skid Fenders protect your customers and skids. They also create a new advertising space.



1 Slide apart to the desired length



2 Connect the interlocking corners



Skid Fender

Skids in a store are an eyesore. Worse, they can be dangerous. Customers can trip over corners or bump into them with shopping carts. Our Skid Fenders protect both shopper and skid by wrapping the sides and corners with a sturdy, attractive bumper. They're also a NEW space for advertising. Skid Fenders expand from 31" to 55" and can be linked together to wrap around any size skid. Available black and red.

SKIDFEN001

Gift Card Spinners



How It Works: Custom Gift Card Spinners

Spinners are a popular way to display and merchandise gift cards. Our creative department can design an eye-catching gift card spinner that's convenient for your customers and space efficient for your retailers.

See more examples of our custom display work at displaypeople.com.





Beverage Systems

We've brewed a new blend of accessories that bring style and functionality to any retail, food service, or office coffee setup.

Whole Bean Merchandising

Entice your customers by showing off your whole bean coffee in our classy and stylish Merchandising Bins. All our Bins feature a patented and durable cast aluminum Dispensing Ball.



700 Series Whole Bean Free Flow Coffee Bins



501 Series Whole Bean Free Flow Coffee Bin



501 Whole Bean Free Flow Coffee Bin

Our 500 Series of Whole Bean Free Flow Coffee Bins utilize our cast aluminum Dispensing Ball on a counter top or wall mountable base. Features chrome plated sign-card holder and lid, branding can easily be added to tubes.

36"H x 6 ³ / ₈ "W x 10"D	18" Tube	FF-501-18
42"H x 6 ³ / ₈ "W x 10"D	24" Tube	FF-501-24



700 Series Whole Bean Free Flow Coffee Bins

Create your own whole bean coffee merchandising system! An elegant European style finish with our cast aluminum Dispensing Ball. Ball Back Plates are available in a hammered gold finish or brushed stainless steel. Specify plate finish when ordering.

16"H x 8"W x 14"D	Capacity: 10-12lbs	FF-704
21"H x 6"W x 14"D	Capacity: 12lbs - Dual Ball Bin	FF-714
21"H x 6"W x 14"D	Capacity: 12lbs	FF-715
14"H x 6"W x 14"D	Capacity: 5lbs	FF-716
16"H x 6"W x 14"D	Capacity: 8lbs	FF-717

Gravity Pot and Merchandise Stands



We have everything you need to create your own Office Coffee Station or Self-Serve System no matter how big or small your operation is.



Condiment Tower

Condiment Tower with 4 removable trays. TR-7 works as a stand-alone unit or with our TR-74 and TR-75 Pot Stands to build your own modular beverage station.

14"H x 8 ¹ / ₈ "W x 8 ³ / ₄ "D	TR-7
--	------

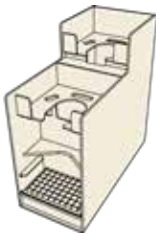
	<p>Short Single Gravity Pot Stand</p> <p>Single Gravity Pot Stand accented with gold trim and features an adjustable high-capacity spill tray. Use with AY-AE25N 2.5L Thermal Gravity Pot.</p> <p>14"H x 8½"W x 8¾"D TR-59</p>
	<p>Single Gravity Pot Stand</p> <p>Our most popular Gravity Pot Stand. Features an adjustable high capacity spill tray, and accented with gold trim. Use with AY-AE25N 2.5L Thermal Gravity Pot, and a TR-7 to build your own modular beverage station.</p> <p>18"H x 8½"W x 8¾"D TR-74</p>
	<p>Double Gravity Pot Stand</p> <p>When one pot is not enough! Features an adjustable high capacity spill tray, and accented with gold trim. Use with two AY-AE25N Thermal Gravity Pots, and a TR-7 to build your own modular beverage station.</p> <p>18"H x 8½"W x 8¾"D TR-75</p>

Condiment Trays

Our Condiment Trays come in different sizes and capacities. Choose the tray that works for your setup or let us design one for you!

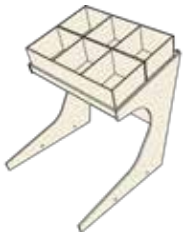
	<p>Single Tier Condiment Tray</p> <p>An all-encompassing condiment organizer with 3 removable, 3 compartment trays, and flanked by 2 detachable, 3 compartment cup/lid/stir stick caddies. Signage is removable. Custom branding available (minimum order required).</p> <p>17¾"H x 21½"W x 15¾"D CT-13</p>
	<p>Second Tier Condiment Tray Add-On</p> <p>Take your CT-13 to a new level with this Second Tier Add-On, complete with 2 removable, 3 compartment trays. Accommodates your CT-13 signage.</p> <p>18¾"H x 13¾"W x 15¾"D CT-14</p>



CT-4 Condiment Tray and Stir Stick Caddy



LH-100-8 Sloped Cup and Lid Holder



CT-15 Two Tier Condiment Tray

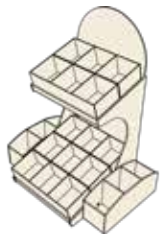

Two Tier Condiment Tray

Our largest Condiment Tray, built for high traffic beverage stations. Complete with 5 removable, 3 compartment trays, flanked by 2 detachable, 3 compartment cup/lid/stir stick caddies and signage. Custom branding available (minimum order required).

29³/₈"H x 21¹/₂"W x 15³/₄"D

With signage

CT-15

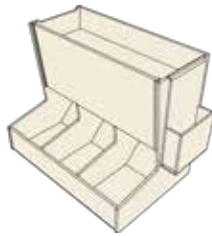

Condiment Tray with Stir Stick Caddy

Keep your condiments organized and accessible. Can be used as a stand-alone unit or linked together to form any size system. Features a clear front window, and removable stir stick caddy.

9⁷/₈"H x 9"W x 7⁷/₈"D

Two compartments

CT-2

9⁷/₈"H x 12⁷/₈"W x 7⁷/₈"D

Three compartments

CT-3

9⁷/₈"H x 16³/₄"W x 7⁷/₈"D

Four compartments

CT-4

Cup & Lid Organizers

Keep your coffee station neat and tidy with our Cup & Lid Organizers.



Three Level Lid Holder

Accommodates up to three variations of lids. Works as a stand-alone unit or use the eyelets for wall mounting or hook and loop for mounting to equipment.

22⁷/₈"H x 5"W x 4¹/₂"D

LH-100-1

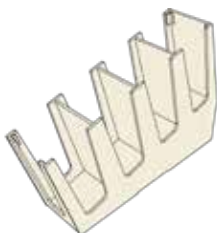

Sloped Cup / Lid Holder

Great for narrow spaces, our Sloped Cup/Lid Holders work with cups / lids up to 3⁷/₈" in diameter.

11¹/₈"H x 4¹/₄"W x 14"D

Three cavity

LH-100-9

12¹/₄"H x 4¹/₄"W x 18"D

Four cavity

LH-100-10

13¹/₄"H x 4¹/₄"W x 22"D

Five cavity

LH-100-8

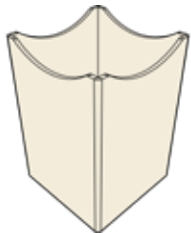
	Stir Stick / Straw Holder Add-On		
	Use as a stand-alone unit or in conjunction with our LH-100-8/9/10 Sloped Cup / Lid Holders to keep stir sticks / straws neat and tidy.		
5 $\frac{5}{8}$ "H x 3 $\frac{3}{4}$ "W x 3 $\frac{3}{4}$ "D		LH-100-SH-1	

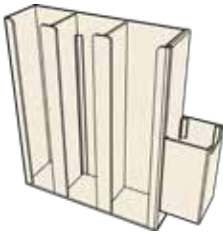
	Three Silo Cup / Lid Holder with Stir Stick Caddy		
	Large capacity cup / lid holder with clip-on Stir Stick/Straw Caddy.		
16"H x 16 $\frac{3}{4}$ "W x 4"D		LO-3	

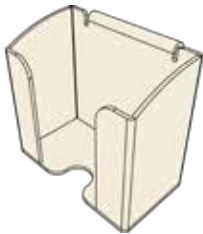
	Clip-On Hot Beverage Sleeve Holder		
	Our injection molded sleeve holder clips onto substrates up to 3/16" thick, such as most of our Cup/ Lid Holders. Can also be used as a stand-alone unit.		
5"H x 5 $\frac{7}{8}$ "W x 3 $\frac{1}{2}$ "D		SLVH-0001	

Accessories

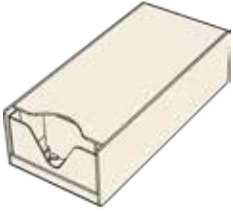
	Hot Beverage Sleeve Pusher		
	Easy to access and refill, keeps your cup sleeves front facing and easily accessible with a built-in spring loaded pusher.		
3 $\frac{1}{2}$ "H x 6 $\frac{1}{4}$ "W x 12 $\frac{1}{2}$ "D		SLVH-0002	

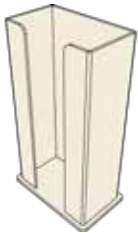
	Hot Beverage Sleeve Holder		
	Keeps your cup sleeves organized and available at your finger-tips. Custom sizes available.		
10 $\frac{1}{4}$ "H x 5 $\frac{3}{4}$ "W x 3 $\frac{1}{2}$ "D		Clear acrylic	HBSH-A
10 $\frac{1}{4}$ "H x 5 $\frac{3}{4}$ "W x 3 $\frac{1}{2}$ "D		Black styrene	HBSH-S



BB01 Espresso Knock Box



LO-3 Three Silo Cup Holder



SLV0002 Sleeve Pusher



SLV0001 Sleeve Holder

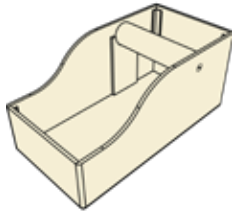

Espresso Knock Boxes

Our Knock Boxes feature an ergonomic design complete with a cushion lined Knock Bar. Perfect for hiding away in a drawer, yet stylish enough to keep on a counter top.

5½"H x 6⅞"W x 12"D

BB01

4"H x 8¼"W x 12"D

BB02



Pastry Case

Fabricated from clear acrylic, complete with dividers and the ability to stack the cases one upon the other.

22½"H x 15¼"W x 22¼"D

BD-15

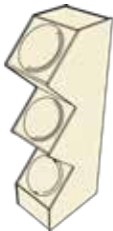

Cutlery Tower

Great for cutlery and condiments alike; the Cutlery Tower can be positioned either vertically or horizontally. Featuring 3 removeable stainless steel canisters and a sliding back door for easy cleaning and storage.

23"H x 5⅞"W x 8 ⅜"D

CT-CS-01

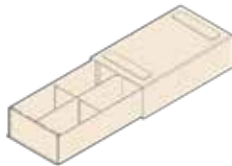

Coffee Pod Box

Made from food-grade styrene. Keep your pods organized in this handy space saving counter unit.

6¼"H x 8¼"W x 13"D

PBD-2D

NEW



Two Pot Thermal Riser

Provides stable and secure resting spot for hot beverage carafes.

1⅞"H x 8⅞"W x 17⅞"D

TR43



RSR-12-6 Syrup Rack



KCUPQUADBIN K-Cup Pod Merchandiser



BD-15 Triple-Tiered Pastry Case



Syrup Rack - Rotating

Made from Food Grade Styrene, our Syrup Racks keep syrup bottles organized and easily accessible.

3"H x 11⁷/₈" Diameter

RSR-12-6

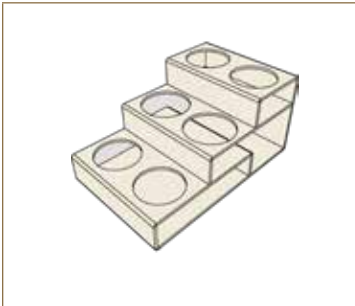

Syrup Rack - Three Tier

Made from Food Grade Styrene, our Syrup Racks keep syrup bottles organized and easily accessible.

6¹/₄"H x 8¹/₄"W x 13"D

SR-1-3

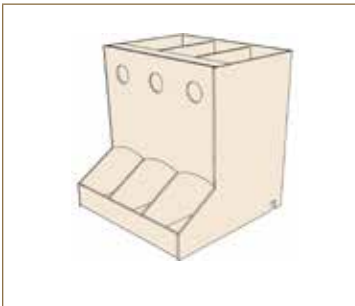

K-Cup Pod Merchandiser

Specially designed for K-Cup pods.

16"H x 14⁵/₈"W x 15"D

KCUPTRIBIN

16"H x 14⁵/₈"W x 15"D

KCUPQUADBIN



NEW

Counter K-Cup Displays

Use with our condiment trays or cup holders.

4³/₄"H x 4³/₄"W x 3³/₈"D

Four Pod Display

KCHLDR-4

6⁵/₈"H x 4³/₄"W x 5"D

Six Pod Display

KCHLDR-6

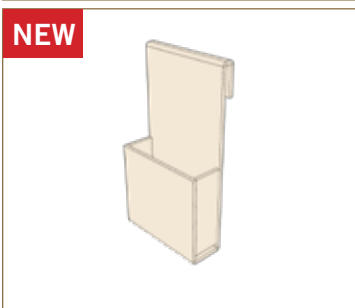

NEW

Straw and Stir Stick Caddies

Use with our condiment trays or cup holders.

6¹/₂"H x 3¹/₂"W x 1¹/₂"D

Stir Stick Caddy

SSH-01

7"H x 3³/₈"W x 3³/₈"D

Straw Caddy

SH-01

NEW



Espresso Cup and Lid Holder

Specially designed to keep espresso cups and lids organized

4 $\frac{1}{8}$ "H x 13 $\frac{3}{8}$ "W x 5 $\frac{1}{2}$ "D

LH100-625

NEW



Tea Box Holder

Keeps tea boxes forward facing and organized.

7"H x 15 $\frac{5}{8}$ "W x 3 $\frac{1}{4}$ "D

MC-TBH-1-V3



Pod Display Rack

Display rack for coffee pods. Swap out the removable top rack and add our tea box holder (MC-TBH-1-V3) for a multi-purpose display solution.

15"H x 17 $\frac{3}{8}$ "W x 11"D

KR-8

NEW



Spill Tray

Coffee bean spill tray to be used with our 500 and 700 series bins.

4"H x 24"W x 7 $\frac{1}{4}$ "D

ST0824



Carafe Riser

Riser for coffee carafe.

8"H x 9 $\frac{1}{4}$ "W x 9"D

TR-41

1 $\frac{1}{2}$ "H x 9 $\frac{1}{4}$ "W x 8"D

TR-1

4 $\frac{1}{8}$ "H x 9 $\frac{1}{4}$ "W x 8"D

TR-2



Pot Stand

Three level coffee carafe stand.

23 $\frac{3}{4}$ "H x 8 $\frac{1}{8}$ "W x 18 $\frac{1}{2}$ "D

TR42



Lighting Systems

Innovative, versatile solutions from the simplest to the most complex retail merchandising and display requirements.

Lighting Parts



Undershelf LED lighting



Lit graphic panel



Back lit cosmetic shelving display



How It Works: LED Shelf Lighting

Integrated shelf lighting improves visibility of the products on display and elevates the brand's image in the mind of the consumer. According to the Lighting Research Center, the use of integrated shelf or point-of-purchase LED lighting also increases the likelihood of a purchase by 40%.

- a** LEDPEN001
Super Slim LED Pencil Light
- b** PSCH001
Power Strip Conector Harness
- c** LVPO01
Low-Voltage Vertical Power Strip
- d** POWSUP001
Power Supply

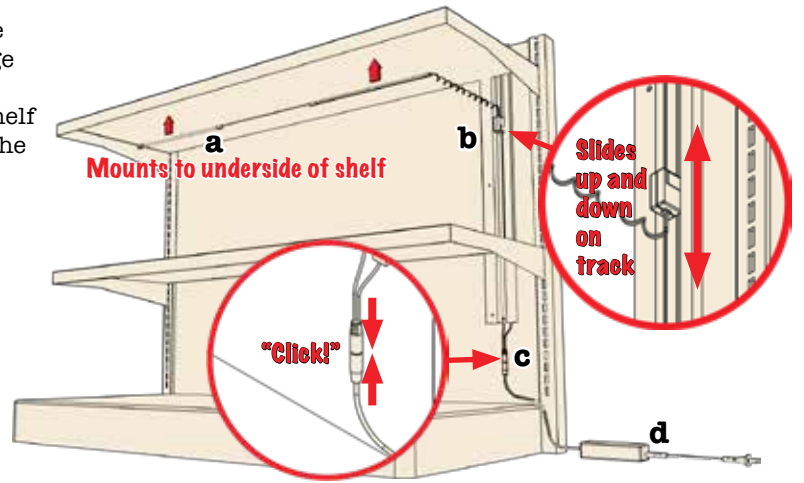

Low-Voltage Vertical Power Strip

Extruded plastic rail can be customized to any length between 24" and 84". Can be mounted vertically against pegboard or horizontally under a shelf. Mounting options: Double sided tape, Push Pins or Metal hardware.

LVPS001

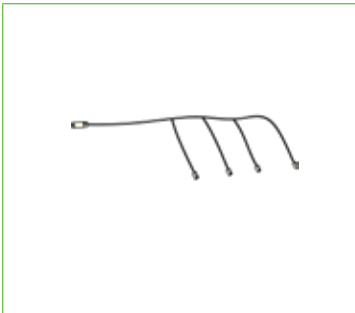

Low Voltage Wire Harness

For use in compact spaces. Customizable up to 7 connections

LVNH001

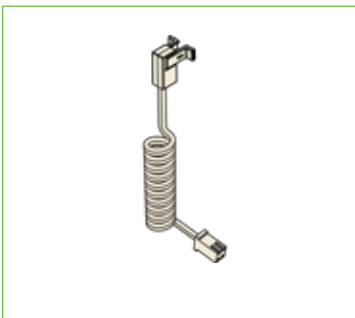

Power Strip Connector Harness

Connects a row of Super Slim LED Pencil Lights to a Vertical Power Strip.

PSCH001



Power Feed - 12"

12" Power Feed, 2.1 DC Jack to Strip Connector

LEDACC001



Male / Female LED Connector

Adds flexible space between Pencil Light segments

MFLEDO01



Power Supply

Type: Class 2
 Input Voltage: 110Vac/220Vac
 Output Power: 100W
 Output Voltage: 24Vdc
 Optional 80W and 60W power supplies available. Option to connect to up to 11 adjacent power supply units.

POWSUP001



Wire Splice Extension Kit

Wire Splice Extension Kit for use with single colour indoor LED strip lights.

LEDACC002



LED Plugin Driver - 60 Watt

This LED Plugin Driver comes with a cord, plug and a 2.1 D.C. jack. Suitable for Indoor LED Tape and LED Strip.

POWER SUPPLY



LED rail cornice lighting







Lit graphic cubes for shelves



Illuminated nail bar and cornices

LED Lights

	<p>Super Slim LED Pencil Light</p> <p>Customizable to meet your needs! LED board is contained within a clear plastic covering. LED strips are offered in multiple lengths. Connect up to 12 Pencil Lights in a row. Mounting options: Magnetic tape, Double sided tape, Brackets. Light Output: 105 Lumens / 12 LEDs per foot Colour Temperature: 6000K - 7000K Longevity: 50,000 hours.</p> <p>4" Shelf Kit LEDPEN001</p>
	<p>High Output LED Tape</p> <p>Outdoor High Output LED Tape that provides ample illumination for residential, retail and any other outdoor application. 54 Watts, 3850 Lumen, 5 Meters Long.</p> <p>Cool White LED001-CW Natural White LED001-NW</p>
	<p>LED Indoor Strip Tape</p> <p>The LED STR Series features 12" linkable, no shadow, end to end joinable sections. Provides high performance illumination for commercial and residential illumination.</p> <p style="text-align: right;">LEDS001</p>
	<p>Indoor LED Pencil Light</p> <p>Colour Changing LED Indoor Tape Light, normal output, 12" linking sections, 3.1Watts/Foot, 120° viewing angle, 18 LED's/12", 70 Lumen/12".</p> <p style="text-align: right;">LED5001</p>
	<p>Outdoor LED Tape</p> <p>The LED STR Series features 12" linkable, no shadow, end-to-end sections. Provides high performance illumination for commercial and residential illumination. Warm 4 Watts - 180 Lumens/Foot Cool 4 Watts – 270 Lumens/Foot</p> <p style="text-align: right;">LEDR001</p>



Lit graphic panel



Nail Bar with LED Lighting

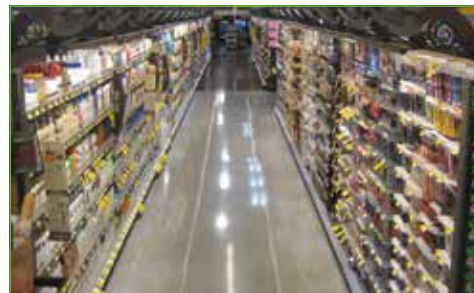

Universal LED cornice lights

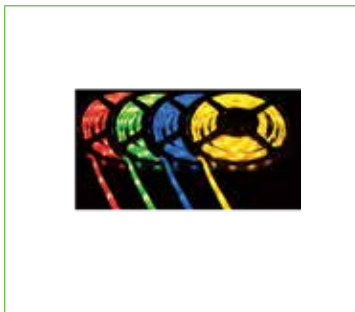

Coloured LED Ribbon

Available in red, blue, green, and yellow. Cut to required lengths in 4" increments. Available in assorted colours (minimum order required).

LEDT

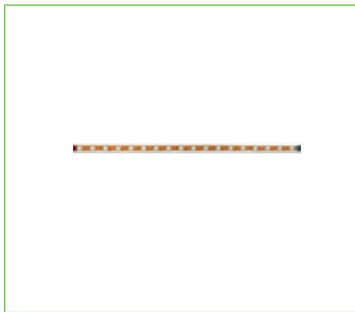

Indoor Colour Changing LED Tape

Normal output, 12" linking sections, 3.1Watts/Foot, 120° viewing angle, 18 LEDs/12", 70 Lumen/12".

LED002-12



Universal Undershelf Light (compression fit)

Impact LED lighting for hot spot lighting in Beauty & Cosmetics. Lots of lumens for visual impact. Easy to install spring activated compression fit on inside of shelf. Energy savings and maintenance free. 50,000 hour life.

LEDUNDS01



Trio Edge Shelf Light

Triple light projection; upward on product, downward on product and shelf edge graphics. Highlights segmentation graphics on front channel. Universal design spring clips to most dairy shelves, even in refrigerated environments and can simply be daisy chained together. Adaptable with standard UPC price tags and secondary store media devices.

TESL001



Universal LED Lit Cornice

Interlocking cornice frame creates soft and elegant curves, inviting to navigate the entire length of the aisle. Portrait style extended cornice features LED lights uniquely configured to emit a warm and consistent flow of directional lighting on all shelves, top to bottom. Segmentation plaques float in between interlocking cornice to help consumers navigate aisle and quickly locate desired product.

UNILED001

PRODUCT INDEX

SIGN HOLDER SYSTEMS

Adjustable Angle Sign Holder	40	Clip-On Wire Sign Holder	48
Aisle Marker	35	Coupon Holder	29
Aisle Sign Holder with C-Clamp	28	Curly Wire Clips	45
Angled Card Holder	41	Custom Frames (Corners and Edging)	35
Basket Clip	39	Double Basket Clip	43
Boot System - D-Tape	44	Double Clip-On Sign Holder	47
Boot System - Heavy Duty Gripper Poster Channel	44	Double Duty Shelf Channel Sign Holder	40
Boot System - Magnetic Base	44	Double Loop UPC / Label Holder	43
Boot System - Thin Poster Channel	44	Dual Frame	36
Bottle Top Holders	15	Elbow - 90°	16
Carton/Basket Clip	18	Flat Base	19
C-Channel Pivoting Connector	18	Flat Shovel Base	19
Center Stem Base	19	Floor Standing Sign Holder	27
Channel Clip Mount	17	Fold-N-Hold Covered Ticket Holder	43
Channel Mount Gripper Sign Holder	28	Fold-N-Hold Flag Sign Holder	40
Channel Mount Gripper Sign Holder - Metal	29	Fold-N-Hold Shelf Channel Flush Sign Holder	39
Clear Angle Base Holder	31	Fold-N-Hold Ticket Holder	43
Clear Card Holder with Base	42	Four-Way Frame Kit	13
Clear Centre Mount Sign Holder	41	Frameless Sign Holder	10
Clear Countertop Adjustable Sign Holder	42	Frame Mount	18
Clear Extruded Hinged Sign Holder	39	Front Loading Aluminum Snap Frame	11
Clear Extruded Sign Holder Clip	39	Gondola Center Flat Base	19
Clear Extruded Wire Basket Card Clip	40	Gondola Center Stem Base	19
Clear Extruded Wire Basket Sign Holder	40	Gondola Upright Metal Telescopic Bracket	37
Clear Grip Sign Holder	41	Hot Pan Clip	46
Clear Inverted T-Sign Holder	31	Imperial Frames	10
Clear L-Angled Sign Holder	32	Large Base Clip	42
Clear L-Shaped Sign Holder	32	Large Flip Number Set	34
Clear Plastic Pin with Large Card Holder	45	Large Hanging Boards	34
Clear Plastic Pin with Memo Clip	45	Magnetic Base-Cross	20
Clear Price Ticket Cube	41	Magnetic Clip-On Sign Holder	48
Clear Sign Frame Adapter	37	Magnetic Header	44
Clear Sign Frame Gripper	37	Magnetic Sign Holder with Gripper	42
Clear Sign Holder	31	Magnetic Stem Base	20
Clear Sign Holder with Metal Base	33	Magnetic Under-Shelf Sign Holder with Gripper	29
Clear Slatwall Foldover Sign Holder	32	Magnetic Under-Shelf Sign Holder with Hinge	29
Clear Spring Coil	30	Male-Male Stem - 90°	16
Clear T-Base Holder	31	Memo Clip with Magnetic Base	41
Clear Tent-Shaped Sign Holder	32	Metal Self-Centering Mount	21
Clear Top Mount Sign Holder	32	Metal Sign Holder	33
Clear T-Shaped Sign Holder	32	Metal Sign Holder with Shovel Base	33
Clear Vinyl C-Channel Sign Holders	11	Metal Threaded Stem	33
Clear Vinyl Foldover Sign Holders	11	Metal Threaded Swege Stem	33
Clear Vinyl Pocket Sign Holders	11	Metric Frames	10
Clear Y-Shaped Sign Holder	33	One Piece Moulded Aisle Marker	35
Clip-In Data Strip Fold N Hold	39	Parallel Magnetic Base	20
Clip-On Adhesive Adapter	47	Pegboard Metal Telescopic Bracket	37
Clip-On Adhesive Adapter for Wire	46	Pegboard / Slatwall Extension Mount	25
Clip-On Extended Sign Holder	47	Pegboard / Slatwall Mount	16
Clip-On Extended Sign Protector	48	Perforated Shelf Card Clip	38
Clip-On Extended Spring Sign Holder	48	Pivoting Sign Clip	38
Clip-On Sign Holder	47	Pivoting Stem Connector	16
Clip-On Sign Holder - 2"	47	POP Sign Holder - Magnetic Base	45
Clip-On Sign Protector	48	POP Sign Holder - Square Base	46
Clip-On Spring Sign Holder	47	POP Sign Holder with T-Clip - Dome Base	46
Clip-On Stem Base	16	Price Spear	45
Clip-On Stem Base for Wire Grid / Basket Frame	15	Reusable Magic Frame	12
		Saddle Clip Mount	17

Self-Centering C-Channel Mount	21	Three-Way Pillar Floor Standing Sign	27
Self-Centering Pegboard / Slatwall Mount	21	Three-Way Sign Holder Kit	13
Self-Centering Under Shelf Swivel Mount	21	Tube-Clip Mount	17
Shelf Bin Holder	22	Under-Shelf Mount Sign Holder	28
Shelf Locking Sign Clip	22	Under-Shelf Mount SuperGrip® Sign Holder	28
Shelf Mount Gripper Sign Holder - Metal	28	Under-Shelf Screw-Mount Gripper Sign Holder	29
Shelf Spring Sign Clip	22	Universal Hang-Rod Clamp	20
Shelf Top Centering Swivel Mount	21	Universal Mount	20
Shelf Top Sign Holder with Frame Holder	36	Wall Mount Clip	20
Shelf Top Sign Holder with Sign Gripper	36	Wide UPC / Label Holder	43
Shopping Cart/Wall Mount Sign Holder	26	Wire / Bin Mount	17
Sidewalk A-Frame	27	Wire Fence Clip	18
Sign Frame with Adjustable Telescopic Pole & Base	22	Wire / Peg Card Clip	38
Sign Frame with Back	10	Wobbler Floor Standing Sign Holder	27
Sign Frame with Centre Stem Base	23	Z-Bar Slatwall Hanging Sign Gripper	43
Sign Frame with Flat Base	23		
Sign Frame with Gondola Stem Base	25	BROCHURE HOLDERS & ACRYLIC ACCESSORIES	
Sign Frame with Magnetic Base	23	Acrylic Cubes	55
Sign Frame with Magnetic Stem Base	24	Ballot Box	55
Sign Frame with Parallel Magnetic Stem Base	26	Card Holder	53
Sign Frame with Pegboard Extension Mount	25	CD/Brochure Holder	50
Sign Frame with Self-Centering C-Channel Mount	24	CD/Brochure Holder with Feet	50
Sign Frame with Self-Centering Undershelf Mount	24	Countertop Book Easel	55
Sign Frame with Self-Centering Undershelf Swivel Mount	24	Euro-Style Green Edge Brochure Holder	52
	24	Extended Pocket Brochure Holder	50
Sign Frame with Shovel Base	24	Four Tier Double Brochure Holder	51
Sign Frame with Suction Cup	25	Four Tier Double Business Card Holder	53
Sign Frame with Two Magnetic Stem Bases	23	Four Tier Slant-Back Brochure Holder	51
Sign Frame with Wall Mount	26	Four Tier Traditional Brochure Holder	52
Sign Frame with Wire Bin Mount	23	Magazine Pocket Holder	50
Sign Riser	36	Plate Holder	55
Single Stem Shovel Base	19	Single Business Card Holder	53
Slatwall Mount	17	Slant-Back Brochure Holder	51
Small Base Clip	42	Slant-Back Wall-Mounted Brochure Holder	50
Small Flip Number Set	34	Slatwall Adjustable Shoe Shelf with Toe Stop	54
Small Hanging Boards	34	Slatwall Magazine Holder	54
Snap-It Sign Holder	39	Slatwall Magazine Holder with Spring Front	54
Spiral Sign Holder	34	Slatwall Magazine Pocket	54
Spring Coil Mount with Gripper Applied	30	Slatwall/Pegboard Shelf	53
Spring Coil with Card Clip	30	Slatwall Shoe Shelf	54
Spring Coil with Extrusion Adapter	30	Slatwall Utility Shelf	54
Standing Bulletin Sign with Flat Base	26	Three Tier Double Wall-Mounted Business Card Holder	53
Standing Bulletin Sign with Trumpet Base	26	Three Tier Slant-Back Brochure Holder	51
Stem	14	Traditional Double Brochure Holder	51
Stem Connector	14	Traditional Wall-Mounted Brochure Holder	52
Stem Mount	14	Two Tier Slant-Back Brochure Holder	51
Stem Mount Reducer	16	Two Tier Wall-Mounted Brochure Holder	52
Strip Mount Card Holder	18	U-Shaped Risers	55
Suction Cup Clip-On Sign Holder	48	Wall Mount Brochure Holder	52
Suction Cup Locking Sign Clip	22	Wide Wall-Mounted Brochure Holder	52
Suction Cup Mount	21		
SuperGrip® Flag C-Channel Card Holder	40	SHELF TICKETING STRIPS	
SuperGrip® Header Sign Holder	37	Angled Card Holder with D-Tape	58
Telescopic Pole Mount	14	Basket Clip	63
The Wobbler	15	Bulk Bin Hinge	61
Threaded Stem Adapter	14	C-Channel Label Holder	58
Three-Way Co-Poly Sign Holder	13	C-Channel Label Holder with Adhesive	59
Three-Way Countertop Sign Holder	13	Clear Dual Extrusion	60
Three-Way Floor Standing Sign Holder	27	Clear Peghook Label Holder	64
Three-Way Frame Connector	13	Clear Wire Bin Holder	63
		Clear Wire Shelf Ticket Channel	60

Double Label Holder	65	Metal Shelf	72
Dual Frame	66	Moulded Dividers	70
Extrusion Label Holder	64	Pusher Front - Bottle	71
Flip Channel - 4"	59	Pusher Front - Clear	71
Flip Label Holder	59	Pusher Front - Curved	71
Flip-Up Label Holder for Shelf Ticket Mouldings - 5"x 3"		Pusher Front - Finger	72
	61	Pusher Front with Label Holder - Clear	71
Flush Sign Holder with Gripper - 1"	63	Shelf Cooler Baffle and Support Bar	73
Glass Mount Shelf Label Holder	61	Small Pusher Front - Clear	71
Glass Shelf Extrusion - 90° Angle	61	Support Bar	73
Glass Shelf Flip-Up Label Holder	64	Wire Dividers	70
Glass / Wood Label Holder	64		
Glass / Wood Label Holder - 45°	64		
Glass / Wood Label Holder - 90°	64		
Gondola Top Card Clip	62		
High Self-Adhesive Data Strip and Label Holder - 2"	58		
High Self-Adhesive Data Strip and Label Holder - 3"	58		
Hinged Basket Clip	63		
Hinged Basket Clip Gripper	60		
Hinged Extrusion	60		
Hinged Label Holder	62		
Label Holder with D-Tape	58		
Label Holder with D-Tape - 3"	61		
Large Hinged Extrusion	60		
Panel Former with Gripper - 60°	65		
Pole Gripper	66		
Shelf Label Holder	59		
Shovel Base Holder	65		
Sign Holder Extrusion with Data Strip	59		
Sign Holder with Gripper	63		
Slatwall Card Holder	62		
Straw Clip - 1"	61		
Tube Holder	66		
Universal Label Holder	66		
Warehouse Aisle Invader	62		
Wire/Basket Shelf Label Holder	60		
Wire Bin Label Holder	62		
Wire Channel Clip	59		
Wire Clip Holder	65		
Wire Flush Sign Holder with Gripper	62		
Wire Sign Holder with Gripper	63		
Z-Bar Slatwall Hanging Sign Gripper	66		

MODULAR MERCHANDISING SYSTEMS

Adjustable Clip-In Divider	86
Adjustable Hanging Pusher System	84
Adjustable Tray Style Pusher Kit	83
Chocolate Bar Pusher Kit	83
Clear Front Fence	94
Condiment Gravity System - 16" Deep	97
Condiment Pusher System - 16" Deep	98
Cosmetics Tray	88
Cosmetic Tray Divider	88
Custom Gravity Wedge	94
Deli / Cheese Pusher Kit - 14" Deep	82
Dividers for Hanging Pusher System	84
Double Pusher Tray Rack	98
Drink Gravity System - 16" Deep	97
Drink Pusher System - 16" Deep	97
DVD/Video Game Pusher Kit	82
DVD / Video Games Pusher Box	91
Extra Wide Paddle	95
Extruded CD / DVD / Video Game Pusher	91
Extruded Divider	94
Extruded End Cap	94
Freezer Pusher Kit - 22" Deep	83
Front Fence - Clear	80
Gen2 Light Duty Pusher for Front Fence - 7/8" Wide	76
Gen2 Light Duty Pusher with Individual Fronts - 7/8" Wide	76
Gen2 Snap-In Adjustable Divider - 2" and 4"	78
Greeting Card Divider	87
Gum Pusher Kit	83
Heavy Duty Divider	78
Heavy Duty Extruded Track	93
Heavy Duty Extruded Track and Divider	93
Heavy Duty Paddle	95
Heavy Duty Pusher - 3" Wide	77
Interlocking Pusher Tray	89
Label Holder Snap Bar	80
Large Adapter Clips	94
Large Clear Divider with T-Shaped Base	87
Large Divider	86
Large Interlocking Pusher Tray	89
Light Duty Extruded Track and Divider	93
Light Duty Paddle	95
Light Duty Pusher - 7/8" Wide	77
Light Duty Pusher - 7/8" Wide	88
Loop Hook Snap-On Pusher	90
Medium Duty Extruded Track and Divider	93
Medium Duty Paddle	95

KWICKLOAD® PUSHER SYSTEM

Adjustable Crossbar	73
Double Curved Pusher Front - Clear	71
Hook Bar C-Clamp with Label Plate	72
Kwickload® Bagged Cheese Kit - Crossbar Mount	73
Kwickload® Brick Cheese Kit - Crossbar Mount	73
Kwickload® Confectionary Kit - Crossbar Mount	74
Kwickload® Crossbar Mounting Kits	70
Kwickload® Deli Kit - Shelf Mount	74
Kwickload® Double Track Bottle Front Kit - Crossbar Mount	74
Kwickload® Double Track Confectionary Kit - Shelf Mount	74
Kwickload® Produce Kit - Crossbar Mount	74
Kwickload® Produce Kit - Shelf Mount	74
Kwickload® Shelf Mounting Kits	70
Large Wide Pusher Front - Clear	72

Medium Duty Paddle with Ridges	95
Medium Duty Pusher - 2" Wide	77
Multi-Use Heavy Duty Pusher	77
Multi-Use Medium Duty Pusher	77
Paper Plate Pusher Kit	83
Pegboard/Slatwall U-Hook - Clear	89
Produce Pusher Kit - 16" Deep	82
Pullout Shelf	85
Pusher Front - Bottle	96
Pusher Front - Clear	96
Pusher Front - Curved	96
Pusher Front - Finger	97
Pusher Track for Hanging Pusher System	84
Rear T-Snap - Punched	80
Rear T-Snap - With Tape	80
Seven Track Pusher Nail Tray	87
Shelf Management Mat	88
Shelf Management Mat Dividers	88
Shelf Mounted Bottle Pusher Kit - 16" Deep	82
Shelf Mount Pusher with Adjustable Dividers	90
Single Hook Snap-On Pusher	90
Slide and Lock Light Duty Pusher Kit	81
Sliding Pin Divider	85
Small Adapter Clips	94
Small Clear Divider with T-Shaped Base	87
Small Divider	86
Small Pusher Front - Clear	96
Snap Bar and Label Holder	80
Snap-In Adjustable Divider - 2"	78
Snap-In Adjustable Divider - 4"	79
Snap-In Adjustable Divider with Front Stops - 2"	79
Snap-In Adjustable Divider with Front Stops - 4"	79
Snap-In Adjustable T-Divider	86
Snap-In Divider - 2"	78
Snap-In Divider - 4"	79
Snap-In Divider with Front Stops - 2"	78
Snap-In Divider with Front Stops - 4"	79
Spice Gravity System - 16" Deep	98
Spice Pusher System - 16" Deep	98
Standard Interlocking Tray	89
Tall Light Duty Paddle	95
Thin Adjustable Clip-In Divider	86
Universal 2" Light Duty Pusher Kit	81
Versa Pusher Clip	91
Wire / Flat Fence U-Hook - Clear	88
Wire Shelf Snap-On Pusher	91
LOSS PREVENTION	
Lock Box	101
Pull-Out Shelf Pusher Kit with Slide Mechanism	101
Secure Merchandiser Shelf	100
Secure Merchandiser Slide Shelf with SlideGuard	100
Security Flip Door with Alarm	101
Shelf Pusher Kit	101
SlideGuard Hardware Kit	102
SlideGuard Panel Kit	102
SlideGuard Standard Kit with Pushers - 16" Deep	102
HANGING RETAILERS	
Adhesive Display Strip	109
Double Hanging Extension Bracket	105
Double-Sided Strip Retailer - 12 Clip	109
Double-Sided Strip Retailer - With and Without Header	109
Durable Vinyl Pouch Strip Retailer	109
Gift Card Extender	110
Gift Card Hanger	110
Hanging Wand Retailer	108
Heavy Duty Moulded Strip Retailers	107
Light Duty Strip Retailer - 12 Clip	108
Locking Strip Retailer with Header	108
Shelf-Top Hook for Flag or Flush Merchandising	105
Single-Sided Strip Retailer	108
Standard Strip Retailer	108
Strip Retailer Mounting Hooks	105
The Extended MAX Hanger	104
The MAX	104
The MAX Bottle Holder - Clear	106
The MAX Bracket for Warehouse Uprights	106
The MAX Butterfly Hook	105
The MAX Card Holder - Clear	106
The MAX Counter Spinner	107
The MAX Extension Bracket	105
The MAX Hanger	104
The MAX Hook	106
The MAX Pegboard and Slatwall Bracket	106
The MAX Universal Bracket	107
The Wobbler	110
DISPLAY COMPONENTS	
Adhesive Pad Roll	113
Adhesive Roll	113
All-Wire Pegboard Hook With Scan Hook	121
All-Wire Pegboard Hook With Scan Plate	122
All-Wire Pegboard Hook With T-Scan Bar	122
Arrow Fastener	131
Arrowhead Thumb Snap	131
Basic Easy-Peel Hang Tab	124
Belly Button Push Pin	130
Butterfly Hook Product Stop	123
Cable Ties	114
Ceiling Grip Clip	126
Ceiling Loop	127
Ceiling Twist Clip	127
Channel Mount Spring Wobbler	116
Christmas Tree Push Pin	130
Clear Bowl with Stem	134
Clear Plastic Tub - 6" Diameter	136
Clip-In Data Strip Fold-N-Hold	116
Corrugate Display Butterfly Hook	117
Corrugated Universal Butterfly Display Hook	117
Corrugated Universal Display Hook	117
Corrugated Universal Display Hook With "C" Channel	120
Corrugated Universal Display Hook With Scan Plate	120
Corrugated Universal Display Hook With T-Scan Bar	121
Cross Base	134
Display Caster	117

Display Foot	116	Ribbed Round Hook	119
Display Hook	119	Rotating Ceiling Hook	126
Display Hook Product Stop	123	Round Inventory Control Unit	123
Display Pole - Corrugate	132	Scanner Hook	120
Display Pole - Metal	132	Screw and Wing Nut Set	131
Display Pole Sign Holder	134	Shelf Support - Four Sided	115
Double C-Hook	128	Shelf Support - Horizontal	114
Double Round Hook	118	Shelf Support - Single	114
Double Round Hook with Tab	118	Shelf Support - Two Piece	114
Easy-Peel Hang Tab	124	Shelf Support - Vertical	114
Edge Protector - Clear	114	Shelf-Top Hook for Flag or Flush Merchandising	122
Elastic Cord with Barbs	128	Sign Clip Adaptor	134
Extra Heavy Duty Magnetic Adapter	113	Sign Holder Pegboard Bracket	116
Fiber Pole Foot	133	Sign Holder Pole Gripper	134
Flexible Hang Tab	124	Sign Holder with Gripper for Display Poles	134
Flexible Hang Tab - Wide	125	Single Prong All-Wire Pegboard Hook	121
Flexible Hinge	115	Slatwall Hanging Bowl	136
Flexible Magnets	112	Snap-Out Pole Base	133
Foam Block Stand-Off	113	Spider Clip	116
Fold-Up Hang Tab	124	Split Ring	112
Four-Tiered 14" Bowl Floor Display	136	Spring Wobbler	116
Four-Tiered 14" Tub Floor Display	136	Squeeze Style Inventory Control Unit	123
Four-Way Wire Carousel	135	Suction Cup with #8-32 Stud and Nut	129
Grippa™ Mushroom Head Suction Cup	129	Suction Cup with Check Hook	129
Handle - Easy Carry	126	Suction Cup with Metal U-Hook	129
Handle Strap - Large	126	Suction Cup with Mushroom Head	128
Handle Strap - Small	126	Suction Cup with Plated Metal Clamp	129
Hang Tab - Cylinder	125	Suction Cup with Thumbtack	129
Hang Tab - Individual	125	Tapered Display Hook With "C" Channel	120
Hang Tab Sheet	125	Tapered Display Hook With Scan Plate	120
Hang Tab Sheet - Wide	125	Three-Way Wire Carousel	135
H-Clip with Gripper	115	Triarama Mobile Kit	127
Heavy Duty Double Loop Hook	118	Trumpet Base	133
Hook Hang Tab	125	Twist-On Clip	128
Hook & Loop Fastener Button Roll	113	Two-Piece Scanner Hook	119
Hook & Loop Fastener Roll	113	Two-Way Clip with Gripper	115
Inventory Control Clip	123	Universal Push Pin	130
Inventory Control Tube	122	Universal Push Pin Remover	131
J-Track and H-Track Sign Holders	115	Utility Cube	136
Knock Down Pole Base	133	Viking Screws	131
Large Easy-Peel Hang Tab	124	Wire and Corrugate Display Butterfly Hook	118
Magnetic Adapter	112	Wire and Corrugate Display Hook	118
Magnetic Adapter with D-Tape	112	Wire and Corrugate Display Hook with C-Channel	119
Metal Grid Clip	128	Wire and Corrugate Display Hook with Scan/Label Plate	119
Mini Triarama Mobile Kit	127	Wire Feet for Display Pole	133
Mini Twist-On Clip	127		
Mobile Spring	127		
Multi-Purpose Clear Bin Dividers	135	MERCHANDISING SOLUTIONS	
Multi-Purpose Clear Bins	135	Adjustable Depth Cosmetic Tray Bracket	139
Octagonal Base	133	Aluminum Post with Grey Base - Satin Finish	145
Pegboard/Slatwall Display Hooks With "C" Channel	120	Ballot Box	149
Pegboard/Slatwall Display Hooks With T-Scan Bar	121	Beverage Holder	142
Plastic Overlap Ring	112	Bowl Divider	145
Plastic Spiral Ring	112	Bowl Divider with Sign Holder	145
Plastic Support Clamp	135	Bucket Display	140
Plastic Turntable	115	Checkout Mat	148
Product Stop - Black	123	Cooler Merchandiser Rack - 16 oz.	143
Quick Grip Washer Fastener	130	Cooler Merchandiser Rack - 20 oz.	143
Ratchet Rivet Fastener	130	Corrugate Powerwing Clip	142
Revolving Clip Strip Display	136	Cosmetics Tray	138

Cosmetic Tray Divider	139	Hot Beverage Sleeve Pusher	155
Countertop Display Bin	149	K-Cup Pod Merchandiser	157
Cube Bin	141	Pastry Case	156
Cup Display	141	Pod Display Rack	158
Deskwindo™	148	Pot Stand	158
Dividers for Adjustable Bin and Tray	140	Second Tier Condiment Tray Add-On	153
DVD/Video Game Pusher Box	146	Short Single Gravity Pot Stand	153
Framed and Hinged Aluminum Slatwall - Satin Finish	145	Single Gravity Pot Stand	153
Hexagonal Dump Bin	148	Single Tier Condiment Tray	153
Large Produce Bin	144	Sloped Cup / Lid Holder	154
Magazine Pocket Holder	146	Spill Tray	158
Merchandiser Rack - Large	143	Stir Stick / Straw Holder Add-On	155
Merchandiser Rack - Small	143	Straw and Stir Stick Caddies	157
Merchandising Bowl	145	Syrup Rack - Rotating	157
Mercury Banner Hanger	147	Syrup Rack - Three Tier	157
Metal Basket	147	Tea Box Holder	158
Metal Tray	147	Three Level Lid Holder	154
Multi-Functional Divider Bin	140	Three Silo Cup / Lid Holder with Stir Stick Caddy	155
Multi-Functional Divider Tray	140	Two Pot Thermal Riser	156
Multi-Functional Tray	146	Two Tier Condiment Tray	154
Multi-Purpose Clear Bin Dividers	138		
Multi-Purpose Clear Bins	138		
Multi-Purpose Tray	138		
Pegboard / Slatwall Adapter	142		
Pegboard / Slatwall U-Hook - Clear	139		
Power Bar	142		
Rectangular Bin	148		
Satin Aluminum Sign Holder with Swivel Mount	146		
Seven-Lane Pusher Nail Tray	140		
Shelf Extender	143		
Skid Fender	150		
Slatwall/Pegboard Frame Holder	140		
Slatwall/Pegboard Powerwing Clip	141		
Slatwall/Pegboard/Wire Shelf Frame Holder	146		
Slatwall Powerwing Clip	141		
Small Produce Bin	144		
Snap Banner Track	147		
Square Bin	149		
Square Window Bin	149		
Three-Face Shelf Spinner	147		
U-Hook - Clear Plastic	141		
U-Hook - Metal	141		
Warehouse Powerwing Clip	142		
Wire Dump Bin	148		
Wire / Flat Fence U-Hook - Clear	139		

LIGHTING SYSTEMS

Coloured LED Ribbon	163
High Output LED Tape	162
Indoor Colour Changing LED Tape	163
Indoor LED Pencil Light	162
LED Indoor Strip Tape	162
LED Plugin Driver - 60 Watt	161
Low-Voltage Vertical Power Strip	160
Low Voltage Wire Harness	160
Male / Female LED Connector	161
Outdoor LED Tape	162
Power Feed - 12"	161
Power Strip Connector Harness	160
Power Supply	161
Super Slim LED Pencil Light	162
Trio Edge Shelf Light	163
Universal LED Lit Cornice	163
Universal Undershelf Light (compression fit)	163
Wire Splice Extension Kit	161

BEVERAGE SYSTEMS

501 Whole Bean Free Flow Coffee Bin	152
700 Series Whole Bean Free Flow Coffee Bins	152
Carafe Riser	158
Clip-On Hot Beverage Sleeve Holder	155
Coffee Pod Box	156
Condiment Tower	152
Condiment Tray with Stir Stick Caddy	154
Counter K-Cup Displays	157
Cutlery Tower	156
Double Gravity Pot Stand	153
Espresso Cup and Lid Holder	158
Espresso Knock Boxes	156
Hot Beverage Sleeve Holder	155

TERMS & CONDITIONS

TERMS OF SALE

- We accept Visa and MasterCard credit cards at time of order. We reserve the right to charge a 3% fee to cover the additional cost associated with credit card transactions.
- Invoice terms: Net 30, subject to credit approval.
- All pricing is subject to change without prior notification.
- We reserve the right to change or improve products without notice.

RETURN POLICY

- All damage or shortage claims must be made within 5 days of ship date. Failure to notify us within 5 days of shipment will constitute the acceptance of the shipment.
- No returns are granted without a return authorization number.
- Unauthorized returns will not be received.
- Customers are responsible for all freight charges related to returns.
- A restock charge of 25% applies to all returns and/or cancellations of catalog items.
- No returns after 30 days from date of shipment.
- No returns on any special work items (i.e. bagged/kitted items, painted items, non-catalog items, custom made items, etc.).
- No returns on items that have been damaged or altered by customer.

SHIPPING INFORMATION

- F.O.B is Concord, Ontario, Canada
- If products are damaged by a freight carrier, please notify the carrier immediately and mark the bill of lading as "damaged." Please then file a claim with the carrier.
- Customers are liable for any costs related to rejected collect freight charges wherein Marketing Impact is not at fault.

LIABILITY NOTICE

- Purchaser assumes all risk of liability and damages due to the improper use of our products.
- It is the responsibility of those who purchase from us, and/or their customers who apply our products, to select the proper part and to test those parts at a level that is commensurate with the nature of the application.
- Marketing Impact Ltd. is not responsible, nor assumes any risk or liability whatsoever, in connection with the products, or combination of the products, contained within.
- Marketing Impact Ltd. makes no warranty, expressed or implied, of any kind related to the use of our products.
- Claims against Marketing Impact Ltd. shall be limited to a refund or credit for the price billed or paid for improper merchandise.
- (All above items are subject to change without notice.)

Over 30 YEARS of eye-catching custom display solutions



www.displaypeople.com

ALWAYS INNOVATING



Your
Source for **Effective**
Display and Merchandising

www.displaypeople.com

1 800 410-0264

sales@displaypeople.com

50 Planchet Road, Concord
Ontario, Canada L4K 2C7