

New KWICKLOAD™ PUSHER SYSTEM

- Ideal for a wide variety of boxed retail products
- Great durability! Made from ABS plastic.

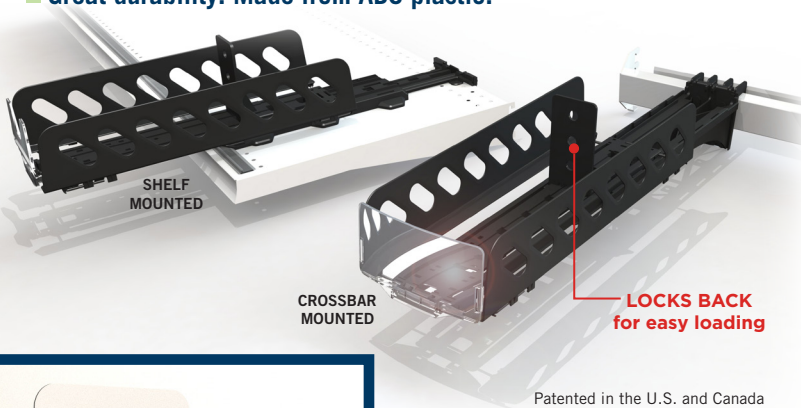

Features & Benefits

Organizes Product Presentation

- Keeps merchandise facing customers

Saves Time and Cost

- Pulls out for fast, no-hassle loading

Helps Reduce Shrinkage

- Prudent addition to retailer's theft deterrence strategy

Fits Many Sizes

- Adjustable dividers accommodate a variety of product widths

Multiple Mounting Options

- Mounting options include crossbar and shelf mounted

